

CASTLE Series

3C3 HD 400-600kVA UPS

USER MANUAL

Thank you for choosing Santak products!

Please adhere to the warnings and instructions specified in the manual and on the equipment, and keep the manual properly for future reference. Do not try to operate the equipment before reading all the safety information and operation instructions

The manual applies to the 3C3 HD series, including:

3C3 HD-400

3C3 HD-500

3C3 HD-600

IMPORTANT SAFETY INSTRUCTIONS

SAVE THESE INSTRUCTIONS

This manual contains important instructions that you should follow during installation and maintenance of the UPS and batteries. Please read all instructions before operating the equipment and save this manual for future reference.



WARNING

This is a product for commercial and industrial application for Level 2 environment. Installation restrictions or additional measures may be needed to prevent disturbances.

© 2022 Santak Corporation

All Rights Reserved

The contents of this manual are the copyright of the publisher and may not be reproduced (even extracts) without the written approval of Santak Corporation. Every care has been taken to ensure the accuracy of the information contained in this manual, but no liability can be accepted for any errors or omission. The right to make design modifications is reserved.

Table of Contents

Chapter 1 SAFETY INSTRUCTIONS	vii
1.1. CE Marking.....	2
1.2. User Precautions.....	2
1.3. Conventions Used in this Manual.....	3
1.4. Environment.....	5
1.5. For More Information.....	5
Chapter 2 INTRODUCTION	6
2.1. Looking Inside the UPS System.....	8
2.2. UPS Operating Modes.....	10
2.2.1. Normal Operating Modes.....	10
2.2.2. Stored Energy and Battery Mode.....	13
2.2.3. Bypass Mode.....	14
2.3. UPS Features.....	15
2.3.1. Advanced Battery Management.....	15
2.3.2. Hot Sync.....	15
2.4. Software and Connectivity Features.....	16
2.4.1. Customer Interface.....	16
2.4.2. Power Management Software.....	16
2.5. Options and Accessories.....	16
2.5.1. External Battery Cabinet (EBC).....	16
2.5.2. Santak Sync Control (Sync Control).....	16
2.6. Battery System.....	16
2.7. Basic System Configurations.....	17
Chapter 3 UPS INSTALLATION PLAN AND UNPACKING	18
3.1. Creating an Installation Plan.....	18
3.2. Site Preparations.....	18
3.2.1. Environmental and Installation Considerations.....	18
3.2.2. UPS System Power Wiring Preparation.....	23
3.2.3. UPS System Interface Wiring Preparation.....	26
Chapter 4 UPS SYSTEM INSTALLATION	27
4.1. Preliminary Installation Information.....	27
4.2. Inspecting and Unpacking the UPS Cabinets.....	27
4.3. UPS System Installation.....	30
4.3.1. Mechanically joining the Cabinet Sections.....	30
4.3.2. Routing Cables.....	31
4.4. Battery System Installation.....	33
4.4.1. Supported Battery Configuration.....	34
4.4.2. Installing the Lithium Battery Cabinet.....	34
4.5. Installing a Remote EPO Switch.....	37



4.6.	Installing Interface Connections	39
4.6.1.	Installing Customer Input Signals Interface	39
4.6.2.	External Battery Breaker Wiring Interface	39
4.6.3.	Relay Output Interface Connections.....	40
4.6.4.	Mini-slot Interface Connections	40
4.6.5.	Installing Signal Interface Connections In Parallel System	40
4.7.	Wiring Parallel 3C3 HD UPS Systems	41
4.7.1.	Power Wiring Overview	41
4.7.2.	Control Signals Overview	44
4.7.3.	Installing Bypass Control Wiring.....	44
4.7.4.	Installing Santak Sync Control.....	46
Chapter 5	COMMUNICATION INTERFACES	47
5.1.	Mini-slots	48
5.2.	Signal input Monitoring.....	50
5.3.	General Purpose Relay Contact.....	50
Chapter 6	UPS OPERATING INSTRUCTIONS	51
6.1.	Ups Controls and Indicators	51
6.1.1.	Control Panel.....	51
6.1.2.	LPS.....	51
6.2.	Control Panel.....	53
6.2.1.	Status Indicators.....	54
6.2.2.	Signing In.....	54
6.2.3.	Home Screen(online).....	56
6.2.4.	Meters.....	59
6.2.5.	Controls	64
6.2.6.	Mimics	67
6.2.7.	Logs.....	69
6.2.8.	Statistics	72
6.2.9.	Settings.....	72
6.3.	System Control Instructions.....	74
6.3.1.	Starting the UPS System in Double Conversion Mode	74
6.3.2.	Starting the UPS System in Bypass Mode	74
6.3.3.	Transfer from Double Conversion Mode to Bypass Mode.....	75
6.3.4.	Transfer from Bypass to Double Conversion Mode.....	75
6.3.5.	Transfer from Double Conversion Mode to Energy Saver System Mode.....	76
6.3.6.	Transfer from Energy Saver System Mode to Double Conversion Mode.....	76
6.3.7.	UPS System and Critical Load Shutdown	76
6.3.8.	De-energizing the Critical Load	77
6.4.	UPS Control Instructions	78
6.4.1.	Starting a Single UPS.....	78
6.4.2.	UPS Shutdown	78
6.4.3.	Enabling and Disabling the Battery Charger	79
6.5.	Using the Remote Emergency Power-off switch	80
6.6.	Transfer the UPS from Double Conversion Mode to Maintenance Bypass Mode.....	81
6.7.	Transfer UPS from Maintenance Bypass to Double Conversion Mode.....	82

Chapter 7 UPS MAINTENANCE	83
7.1. Important Safety Instructions.....	83
7.2. Performing Preventive Maintenance	84
7.2.1. DAILY Maintenance	84
7.2.2. MONTHLY Maintenance.....	84
7.2.3. PERIODIC Maintenance.....	84
7.2.4. ANNUAL Maintenance.....	85
7.2.5. BATTERY Maintenance.....	85
7.3. Recycling the Used UPS or Batteries.....	85
7.4. Maintenance Training	85
Chapter 8 TECHNICAL DATA	86
8.1. Standards	86
8.2. UPS System Input.....	87
8.3. UPS System Output	87
8.4. Battery Specification.....	88
8.5. UPS Environmental Specifications.....	88
Chapter 9 WARRANTY	90
Chapter 10 INSTALLATION CHECKLIST	91
Chapter 11 APPENDIX A: USER SETTINGS	93



List of Figures

Figure 2-1: Santak 3C3 HD UPS.....	6
Figure 2-2: Components Layout	7
Figure 2-3: 3C3 HD UPS Wiring Diagram	9
Figure 2-4: Path of current through the UPS in Double Conversion Mode	11
Figure 2-5: Path of current through the UPS in Energy Saver System	12
Figure 2-6: Path of current through the UPS in Battery Mode.....	13
Figure 2-7: Path of current through the UPS in Bypass Mode	14
Figure 3-1: UPS Cabinet Clearances. See Table 3-2	20
Figure 3-2: UPS Dimensions	22
Figure 4-1: Straighten the Securing Tabs	29
Figure 4-5: Fork into Position	29
Figure 4-4: Remove the fixing screw	29
Figure 4-2: Remove Wooden Box	29
Figure 4-3: Remove Cushioning.....	29
Figure 4-6: Gland Plate and Connector Locations	32
Figure 4-7: Separate Battery Configurations and Common Battery Configurations	36
Figure 4-8: Normally-Open REPO Switch Wiring	37
Figure 4-9: Normally-Closed REPO Switch Wiring.....	38
Figure 4-10: Principle of Paralleled UPS Systems	43
Figure 4-11: Simplified CAN and Pull-Chain Wiring for Parallel UPS System.....	44
Figure 4-12: CAN and Pull-Chain Wiring for Parallel UPS	45
Figure 4-13: Sync Control TB1 Terminal Location.....	46
Figure 5-1: Communication Interfaces	47
Figure 5-2: Gigabit Network Card.....	48
Figure 5-3: Environmental Monitoring Probe generation 2 (EMPG2).....	48
Figure 5-4: Industrial Gateway Card.....	49
Figure 5-5: Relay Card-MS.....	49
Figure 6-1: UPS Controls and Indicators.....	52
Figure 6-2: UPS Color Touch screen Control Panel (Typical)	53
Figure 6-3: Parts of the Touch Screen.....	55
Figure 6-4: Sign In or Password Request Screen	55
Figure 6-5: Home Screen	57
Figure 6-6: Output kVA Screen from Home Screen.....	57
Figure 6-7: Average Efficiency Screen from Home Screen	58
Figure 6-8: Consumption Screen from Home Screen	58
Figure 6-9: Meters Summary Screen	59
Figure 6-10: Input Meters Screen.....	59
Figure 6-11: Bypass Meters Screen	60
Figure 6-12: Output Meters Screen	60
Figure 6-13: Input Meters Detail Screen.....	61
Figure 6-14: Online Mode Metering Method Option Screen.....	61
Figure 6-15: Select Source Screen	61
Figure 6-16: Battery Meters Screens.....	62
Figure 6-17: Battery Voltage Screens.....	62
Figure 6-18: Battery Current Screens.....	62
Figure 6-19: Lithium battery measurement screen.....	63

Figure 6-20: Lithium battery interface.....	63
Figure 6-21: System Controls Screen	64
Figure 6-22: UPS Controls Screen.....	64
Figure 6-23: Module Controls Screen.....	65
Figure 6-24: Module Control Detail Screen	65
Figure 6-25: Turn On Charger confirmscreen.....	65
Figure 6-26: Energy Advantage Architecture (EAA) Screen.....	66
Figure 6-27: Enable ESS Confirmscreen	66
Figure 6-28: Enable VMMS Confirmscreen.....	66
Figure 6-29: Enable ABM Confirmscreen	67
Figure 6-30: Clear Alarms Confirmscreen	67
Figure 6-31: UPS Mimic Screen	67
Figure 6-32: UPS Module Map Screen.....	68
Figure 6-33: System Overview Screen.....	68
Figure 6-34: ESS Screen.....	68
Figure 6-35: System Events Screen.....	69
Figure 6-36: System Log Screen.....	70
Figure 6-37: Active Event Detail Screen.....	70
Figure 6-38: Service Log Screen.....	71
Figure 6-39: Change Log Screen	71
Figure 6-40: Statistics Data Detail Screen.....	72
Figure 6-41: User Screen Screen.....	72
Figure 6-42: Configuration Options Screen.....	73
Figure 6-43: Prompt for level 3 Password Screen.....	73
Figure 6-44: Double Conversion Mode.....	81
Figure 6-45: Maintenance Bypass Mode.....	81
Figure 6-46: Maintenance Bypass Mode.....	82
Figure 6-47: Double Conversion Mode.....	82
Figure 7-1: WEEE Symbol.....	85
Figure 7-2: Recycling Batteries Symbol	85



List of Tables

Table 1-1: Acronyms and Abbreviations	4
Table 2-1: Standard and Optional UPS Options	17
Table 3-1: Dimensions and Weights	19
Table 3-2: UPS Cabinet Minimum Clearances	20
Table 3-3: Air conditioning or Ventilation Requirements During Full Load Operation	21
Table 3-8: Maximum Recommended Multi-core Cable Sizes (unit:mm ²)	24
Table 3-9: Minimum Recommended Multi-core Cable Sizes (unit:mm ²)	24
Table 3-10: Rated and Maximum Currents for Rated Power and Voltage (unit:A)	24
Table 3-11: UPS Power Cable Terminations.....	25
Table 4-1: Normally-Open REPO Connections and Wire Terminations.....	37
Table 4-2: Normally-Closed REPO Connections and Wire Terminations	38
Table 4-3: Dry Contact Output Terminal	40
Table 6-1: Status Indicator	52
Table 6-2: Status Indicator	54
Table 6-3: Security Levels and Functions.....	56
Table 6-4: UPS Menu Structure.....	56
Table 8-1: Standards	86
Table 8-2: UPS System Input	87
Table 8-3: UPS System Output.....	87
Table 8-4: Battery Specification	88
Table 8-5: UPS Environmental Specifications	88
Table 8-6: Information copied from Table B1 of ANSI/ISA-71.04-2013 for G1 equipment.....	89
Table 8-7: Meet the transportation and storage environment requirements.....	89
Table 11-1: User Settings	93
Table 11-2: Config Settings.....	93

Chapter 1 SAFETY INSTRUCTIONS

IMPORTANT SAFETY INSTRUCTIONS SAVE THESE INSTRUCTIONS

This manual contains important instructions that should be followed during installation and maintenance of the UPS and batteries. Please read all instructions before operating the equipment and save this manual for future reference. The UPS operates with mains, battery or bypass power. It contains components that carry high currents and voltages. The properly installed enclosure is earthed and IP20 rated against electrical shock and foreign objects. However, the UPS is a sophisticated power system and only qualified personnel is allowed to install and service the UPS.



WARNING

- **Operations inside the UPS must be performed by a service engineer from the manufacturer or from an agent authorized by the manufacturer.**
 - **This UPS contains LETHAL VOLTAGES. All repairs and service should be performed by AUTHORIZED SERVICE PERSONNEL ONLY. There are NO USER SERVICEABLE PARTS inside the UPS.**
-



WARNING

- **The UPS is powered by its own energy source (batteries). The output terminals may be energised even when the UPS is disconnected from an AC source. To reduce the risk of fire or electric shock, install this UPS in a temperature and humidity controlled, indoor environment, free of conductive contaminants. Ambient temperature must not exceed 40°C (104°F). Do not operate near water or excessive humidity (95% maximum). The system is not intended for outdoor use.**
 - **Ensure all AC and DC power sources are disconnected before performing installation or service. Power may come from multiple sources.**
 - **In parallel system, output terminals may be energised even when the UPS is turned off.**
 - **Ensure system grounding/PE continuity when undertaking installation or service.**
 - **Batteries can present a risk of electrical shock or burn from high short-circuit current.**
 - **ELECTRIC ENERGY HAZARD. Do not attempt to alter any battery wiring or connectors. Attempting to alter wiring can cause injury.**
 - **Do not open or mutilate batteries. Released electrolyte is harmful to the skin and eyes. It may be toxic.**
 - **IMPORTANT: the battery may consist of multiple parallel strings, disconnect all strings before installation.**
-



CAUTION

- Installation or servicing should be performed by qualified service personnel knowledgeable of batteries and required precautions. Keep unauthorized personnel away from batteries. Consider all warnings, cautions, and notes before installing or replacing batteries. **DO NOT DISCONNECT** the batteries while the UPS is in Battery Mode.
- Replace batteries with the same number and type of batteries as originally installed in the UPS.
- Disconnect the charging source prior to connecting or disconnecting terminals.
- Determine if the battery is inadvertently grounded. If it is, remove the source of the ground. Contacting any part of a grounded battery can cause a risk of electric shock. An electric shock is less likely if you disconnect the grounding connection before you work on the batteries.
- Proper disposal of batteries is required. Refer to local codes for disposal requirements.
- Do not dispose of batteries in a fire. Batteries may explode when exposed to flame.
- Keep the UPS door closed and front panels installed to ensure proper cooling airflow and to protect personnel from dangerous voltages inside the unit.
- Do not install or operate the UPS system close to gas or electric heat sources.
- The operating environment should be maintained within the parameters stated in this manual.
- Observe all DANGER, CAUTION, and WARNING notices affixed to the inside and outside of the equipment.



CAUTION

To prevent damage to the wiring channel and wiring in the UPS cabinet base when lifting or moving the cabinet:

- Lift and move the cabinet using only the front or rear forklift slots.
- Verify that the forklift forks are in a horizontal position before inserting them into the forklift slots. **DO NOT** angle fork tips upward.
- Insert the forks all the way through the base. **DO NOT** insert forks partially into the base to move the cabinet.
- Forks may be partially inserted into the front or rear forklift slots for minor positioning if the forks are kept in a horizontal position with no upward angling.
- **DO NOT** use the forklift slots on the end of the cabinet to move the cabinet.
- End forklift slots may be used for minor positioning if the forks are kept in a horizontal position with no upward angling.

If these instructions are not followed, damage to the wiring channel and wiring will occur.

1.1. CE Marking

The product has the CE marking in compliance with the following European directives:

- LV Directive (Safety) 2014/35/EU
- EMC Directive 2014/30/EU

Declaration of conformity with UPS harmonised standards and directives EN 62040-1 (Safety) and EN 62040-2 (EMC) are available at <http://powerquality.Santak.com> or by contacting your nearest Santak office or authorized partner.

1.2. User Precautions

The only user operations permitted are:

- Start up and shut down of the UPS, excluding the commissioning start up.
- Use of the HMI control panel.
- Use of optional connectivity modules and their software.

The user must follow the precautions and only perform the described operations. Any deviation from the instructions could be dangerous to the user or cause accidental load loss.



WARNING

The user is not permitted to open any screws excluding connectivity plates and the MBS locking plate. Failure to recognise the electrical hazards could prove fatal.



CAUTION

- **The 3C3 HD series models are available as C2 UPS product which can be placed both in a residential and commercial/industrial environment. When included in a residential environment, this product may cause radio interference, in which case the user may be required to take additional measures.**
 - **By standard, the 3C3 HD series models are category C3 UPS products, meant for all commercial and industrial establishments.**
-



1.3. Conventions Used in this Manual

The intended audience of this manual are people who plan the installation, install, and use the UPS and UPS Module. This manual provides guidelines for checking the delivery, installing, and operating of the UPS.





The reader is expected to know the fundamentals of electricity, wiring, electrical components and electrical schematic symbols. This manual is written for a global reader.



NOTE

Read the manual before operating or working on the UPS.

The following are examples of symbols used on the UPS or accessories to alert you to important information:

Bold type	Bold Type -highlights important concepts in discussions, key terms in procedures, and menu options, or represents a command or option that you type or enter at a prompt.
	RISK OF ELECTRIC SHOCK - Indicates that a risk of electric shock is present and the associated warning should be observed.
	CAUTION: REFER TO OPERATOR'S MANUAL - Refer to your operator's manual for additional information, such as important operating and maintenance instructions.
	Information notes call attention to important features or instructions.
	This symbol indicates that you should not discard the UPS or the UPS batteries in the trash. This product involves sealed, lead-acid batteries and must be disposed of properly. For more information, contact your local recycling/reuse or hazardous waste center.
	This symbol indicates that you should not discard waste electrical or electronic equipment (WEEE) in the trash. For proper disposal, contact your local recycling/reuse or hazardous waste center.

The following abbreviation may appear in the manual. You are suggested to understand the symbols and their meanings.

Table 1–1: Acronyms and Abbreviations

Terminology	Description
UPS	Uninterruptible Power System
UPS system	The entire power protection system – the UPS cabinet, the battery cabinet, and options or accessories installed.
UPM	Universal power module
STS	Static transfer switch
CM	communication module
HMI	Human Machine Interface
EPO switch	Emergency Power Off switch
MBS	Maintenance Bypass Switch
REPO	Remote Emergency Power Off
EAA	Energy Advanced Architecture
ESS	Energy Saver System
VMMS	Variable Module Management System
ABM	Advanced Battery Management
IO cabinet	Cabinet for wiring
UPM cabinet	The cabinet used to install UPM
K1	Input relay
K2	Battery relay
K3	Inverter relay
K5	Integrated backfeed protection



1.4. Environment

The UPS must be installed according to the recommendations in this manual. Under no circumstances should the UPS be installed in an airtight room, in the presence of flammable gases, or in an environment exceeding the specifications.

Excessive amount of dust in the operating environment of the UPS may cause damage or lead to malfunction. The UPS should always be protected from the outside weather and sunshine. In order to maximize internal battery service life time, the recommended operating temperature range is from +20 to +25 °C.



WARNING

Hydrogen and oxygen gases are emitted from batteries into the surrounding atmosphere during charge, float charge, heavy discharge, and overcharge. Explosive gas mixture may be created if the hydrogen concentration exceeds 4% by volume in air. Necessary air flow rate for ventilation of UPS location must be ensured.

1.5. For More Information

Address any inquiries about the UPS and battery cabinet to the local office or agent authorized by the manufacturer. Please quote the type code and the serial number of the equipment. Call your local service representative if help is needed with any of the following:

- Scheduling initial startup
- User's and Installation Guide
- Regional locations and telephone numbers
- A question about any of the information in this manual
- A question this manual does not answer

Chapter 2 INTRODUCTION

Santak 3C3 HD UPS series uninterruptible power supply (UPS) is a true online, continuous-duty, transformerless, double-conversion, that supplies conditioned and uninterruptible AC power to critical load and protects it from power failures.

Santak 3C3 HD 400-600 kW UPS has flexible power scalability from 400 kW to 4.8MV, high flexibility and applicability, market leading efficiency, availability and performance, small-middle-large data center, automation, medical etc. to protect power and customized power system solution.

Each UPS cabinet provides a system static bypass.

For product models, see [Table 8-1](#).



NOTE

Startup and operational checks must be performed by an authorized Santak Customer Service Engineer, or the warranty terms specified in [Chapter 9](#) become void. This service is offered as part of the sales contract for the UPS. Contact service in advance (usually a two-week notice is required) to reserve a preferred startup date.

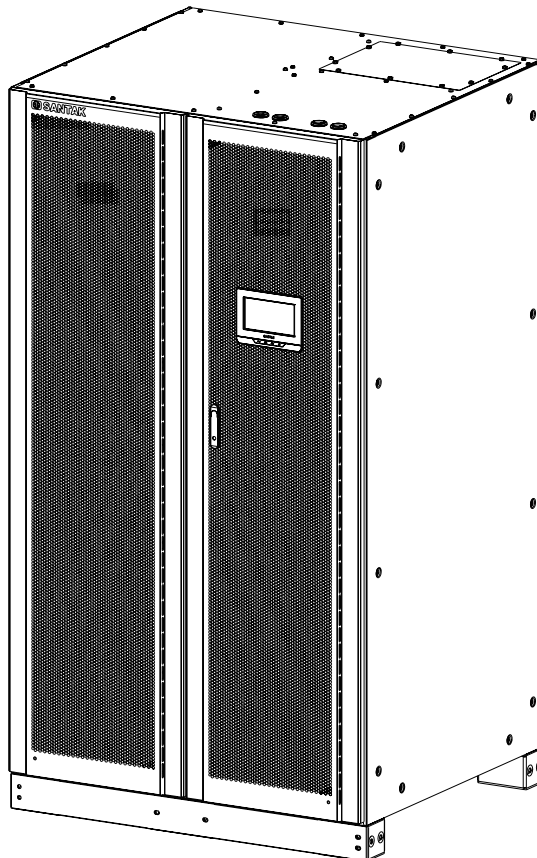

Figure 2-1: Santak 3C3 HD UPS

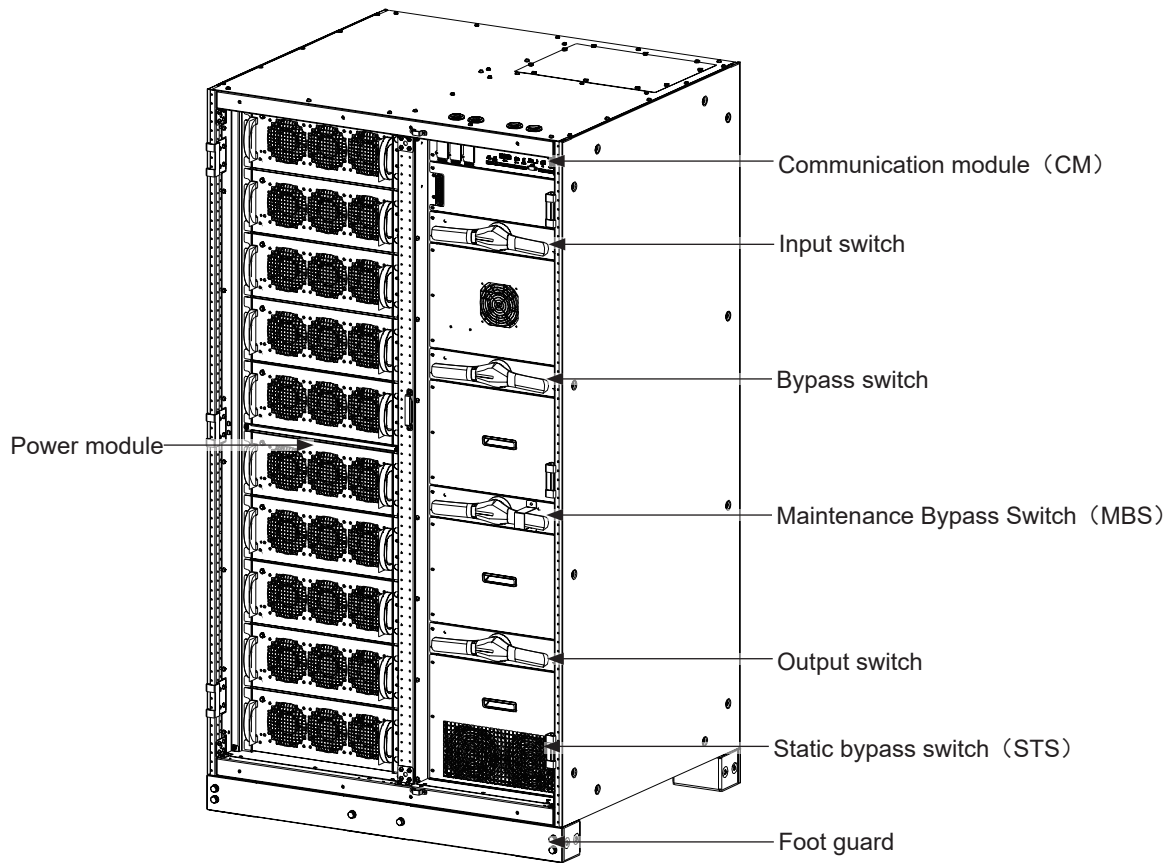

Figure 2-2: Components Layout

2.1. Looking Inside the UPS System

The system level static bypass in the 3C3 HD series UPS determines the attainable output power of the UPS. The static bypass line consists of static switch and a backfeed protection isolation device connected in series. In addition, there is a system level control unit that constantly monitors the power delivered through the bypass line or to the input of the UPS. Transfers to static bypass are seamless and performed automatically by the system as needed, for example, in case of an extended system overload.

3C3 HD UPS includes rated static bypass module, Configurable rectifier input switch, output switch, internal maintenance bypass switch and bypass switch, These units do not include internal batteries. For the structure diagram of the UPS cabinet, please refer to [Figure 2-3](#).

Power module includes a rectifier, inverter, battery converter, and independent controls.

For optional configuration, see section [2.5 Options and Accessories](#)

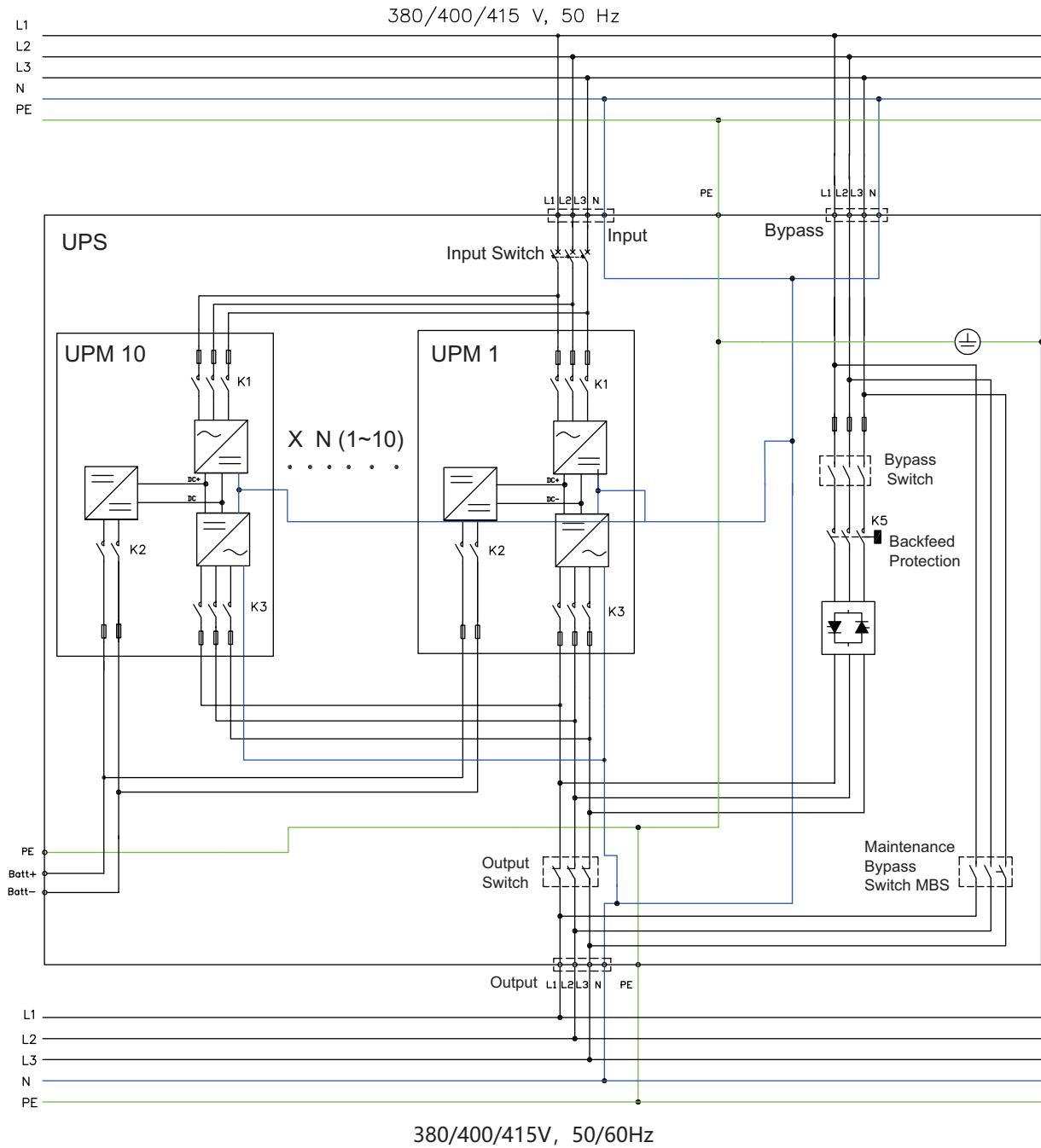

Figure 2-3: 3C3 HD UPS Wiring Diagram

If utility power is interrupted or falls outside the range specified in [Chapter 8](#), the UPS uses a backup battery supply to maintain power to the critical load for a specified period of time until the utility power returns. For extended power outages, the UPS allows you to either transfer to an alternative power system (such as a generator) or shut down your critical load in an orderly manner. The UPS bypass consists of a continuous-duty static switch and backfeed protection isolation device K5. The backfeed protection is located in series with the static switch. Transfers to static bypass are seamless and performed automatically by the system as needed, for example, in case of an extended system overload.

2.2. UPS Operating Modes

UPS operating modes:

- Normal operating modes:
 - In Double Conversion Mode, the critical load is supplied by the inverter, which derives its power from rectified utility AC power. In this mode, the battery charger also provides charging current for the battery, if needed.
 - In Energy Saver System (ESS) mode, the critical load is supported securely by utility power through static bypass switch with double conversion available on-demand with typically less than a 2 milliseconds transition time, should any abnormal condition be detected in the utility. When operating in ESS mode, the load is protected with inherent surge suppression. Operating the UPS in ESS mode increases system efficiency to 99% allowing
- In stored energy mode, the energy is drawn from a DC backup power source and converted to AC power by the UPS inverter. Most commonly VRLA batteries are introduced to the system for this purpose, and the mode of operation is called Battery Mode.
- In Bypass Mode, the critical load is supported directly bypass input power through the UPS static switch.

2.2.1. Normal Operating Modes

During normal UPS operation, power for the system is derived from a utility input source. “Unit Online” is displayed on the front panel, indicating that the incoming power is within voltage and frequency acceptance windows.

Double Conversion Mode

[Figure 2-4](#) shows the path of electrical power through the UPS system when the UPS is operating in Double Conversion Mode.

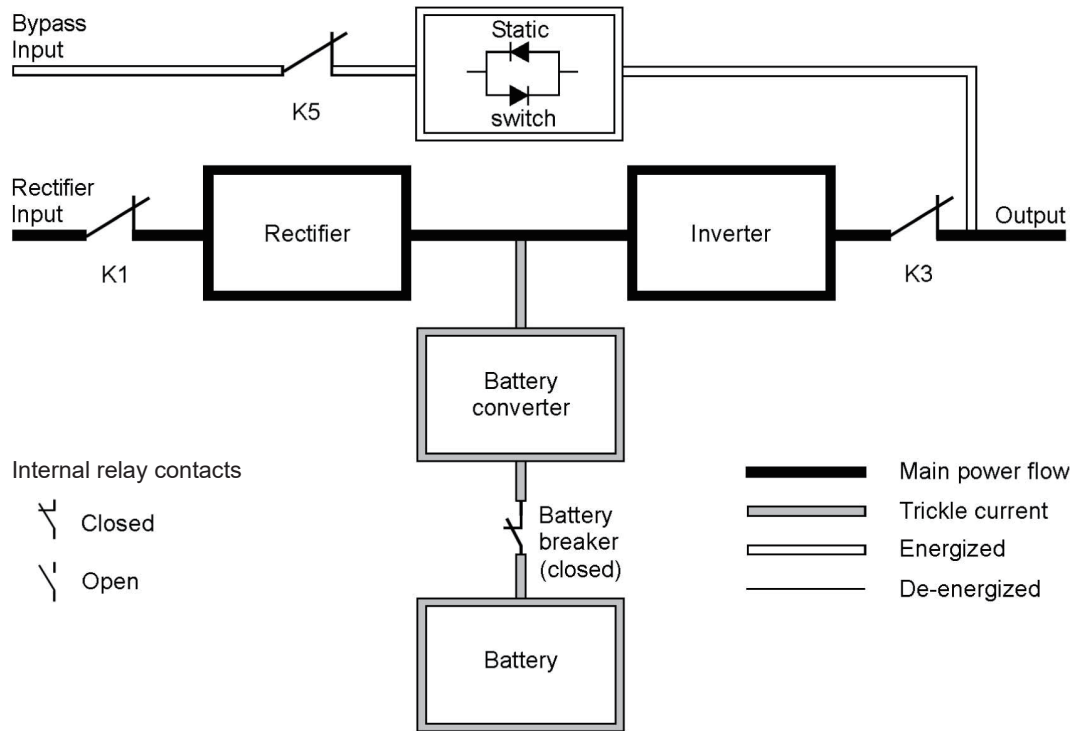

Figure 2-4: Path of current through the UPS in Double Conversion Mode

Three-phase AC input power is converted to DC using a multilevel converter with IGBT devices to produce a regulated DC voltage to the inverter. The UPS status indicated on the display is “Unit Online” and the UPS status is “Active”.

The battery converter derives its input from the regulated DC output of the rectifier and provides regulated charge current to the battery. The battery is always connected to the UPS and ready to support the inverter should the utility input become unavailable.

The inverter produces a three-phase AC output to the critical load. The inverter derives regulated DC from the rectifier and uses multilevel converter technology with IGBT devices and pulse-width modulation (PWM) to produce a regulated and filtered AC output.

If the utility AC power is interrupted or is out of specification, the UPS automatically switches to Battery Mode to support the critical load without interruption. When utility power returns, the UPS returns to Double Conversion Mode automatically.

If the UPS suffers inverter overload exceed the allowance timer, the UPS seamlessly switches to Bypass Mode and continues supplying the load through the static bypass. The UPS automatically returns to Double Conversion Mode when the abnormal condition, such as an extended time overload, is cleared and system operation is restored within specified limits.

If there is no redundancy between the UPS due to high load level, the UPS switches automatically to Bypass Mode and remains in that mode, And remain in bypass mode until maintenance to correct the failure and restore the UPS to normal.

In an external parallel redundant system, each one UPS can be isolated from the system for service while the remaining UPSs support the load in double conversion.

Energy Saver System Mode

In ESS mode the UPS safely provides mains current directly to the load when the input is within the acceptable limits by its voltage and frequency. The UPS status indicated on the display is “Unit Online ESS”, and the UPS status is “Active”. Basic surge protection and noise filtering is also provided, ensuring that clean power is delivered to the load equipment. Should there be any disturbances detected in the incoming power, the UPS switches to double conversion and continues to supply the critical load through its inverter. In case of a complete utility outage or if input power is outside the tolerances of the system, the UPS transfers to Battery Mode and continues to supply conditioned, clean power to the critical load.

When operating in ESS, the UPS superior detection and control algorithms continuously monitor incoming power quality and allow the fast engagement of power converters. Typical transition time to double conversion is less than 2 milliseconds, which is practically seamless to the critical loads.

When power conditions are within acceptable limits, the UPS operates as a high-efficiency, energy saving system — providing surge protection for IT equipment and ensuring clean power is delivered to the facility. Energy Saver System increases system efficiency upto 99% when supplying 20-100% nominal load, reducing energy losses by up to 80%.

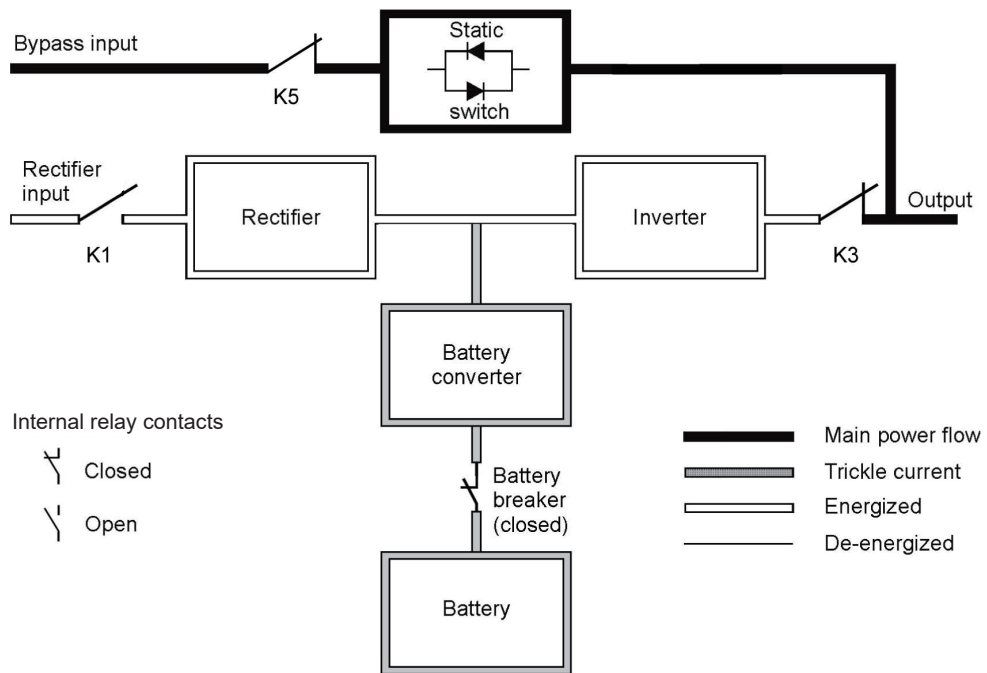

Figure 2-5: Path of current through the UPS in Energy Saver System



2.2.2. Stored Energy and Battery Mode

When running normally in double conversion or ESS mode, the UPS automatically transfers to supply the load from batteries or other stored energy source if a utility power outage occurs, or if the utility power does not conform to specified parameters. The UPS status indicated on the display is “On Battery”, and the UPS status is “Active”. In Battery Mode, the battery provides emergency DC power which is converted to regulated output power by the inverter. *Figure 2-6* shows the path of electrical power through the UPS system when operating in Battery Mode.

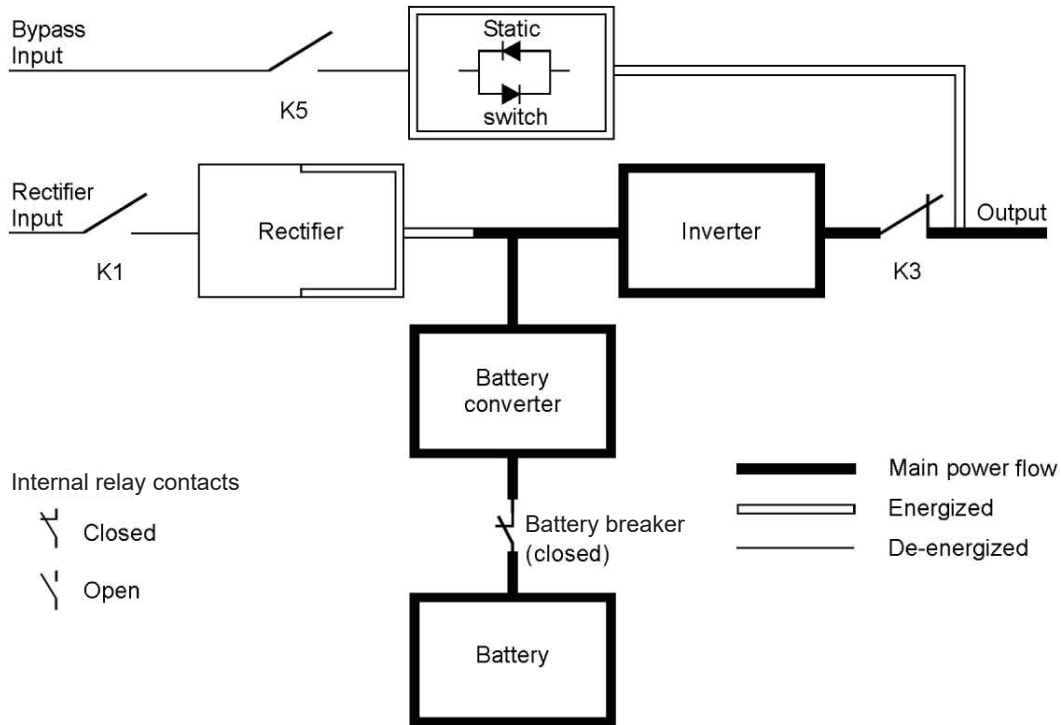

Figure 2-6: Path of current through the UPS in Battery Mode

During a utility power failure, the rectifier no longer has an AC utility source from which to supply the DC output current required to support the inverter. The input relay K1 opens and the UPS output is powered from batteries through the inverter. As the inverter operates uninterrupted through the transition, the load remains supported continuously without disturbance. If the UPS static bypass is supplied from the same source as the UPS rectifier, the backfeed protection contactor K5 also opens. The opening of K1 and K5 prevent system voltages from bleeding backwards and re-entering the input source through the static switch or rectifier.

If the input power fails to return or is not within the acceptance windows required for normal operation, the battery continues discharging until a DC voltage level is reached where the inverter output can no longer support the connected loads. When this event occurs, the UPS issues a set of audible and visual alarms indicating that the batteries are having a minimal capacity left and a system shutdown is imminent. Unless utility power is restored, the output can be supported for maximum two minutes before the output of the system shuts down. If

the bypass source is available, the UPS transfers to bypass instead of shutting down.

If at any time during the battery discharge the input power becomes available again, K1 and K5 close and the UPS returns to normal operation. The UPS will also start to recharge batteries to restore the capacity.

2.2.3. Bypass Mode

The UPS automatically switches to Bypass Mode if it detects an overload, load fault, or internal failure. The bypass source supplies the commercial AC power to the load directly. The UPS can also be commanded to transfer to bypass manually through the display. The UPS status indicated on the display is “On Bypass”. [Figure 2-7](#) shows the path of electrical power through the UPS system when operating in Bypass Mode.



NOTE

The critical load is not protected while the UPS is in Bypass Mode.

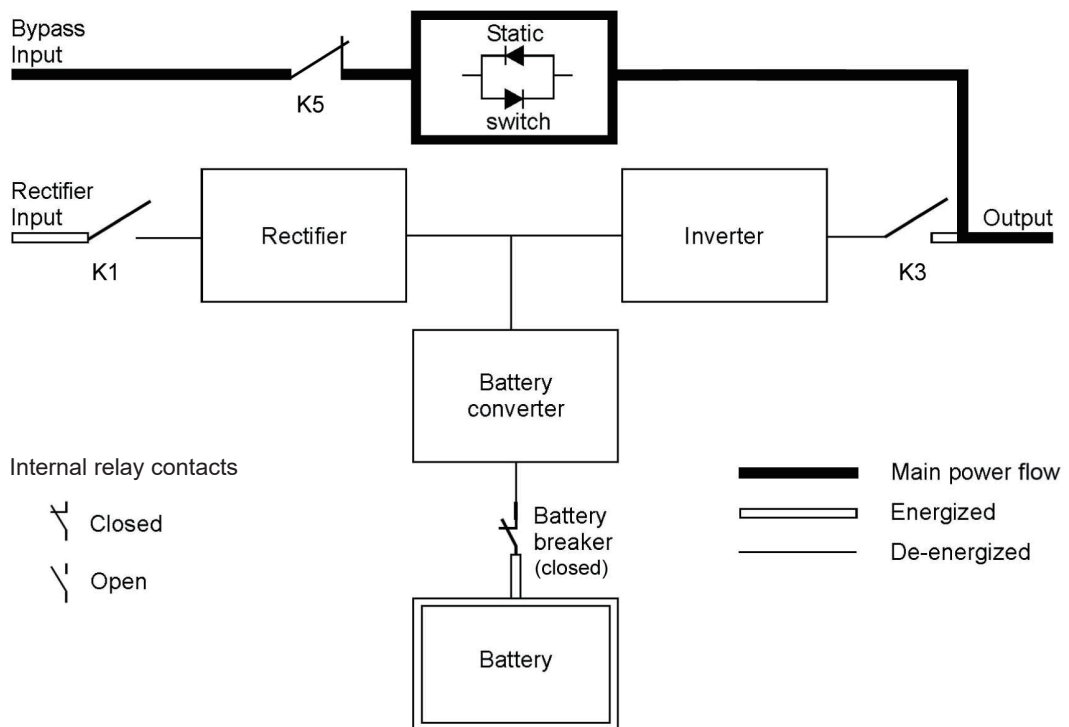

Figure 2-7: Path of current through the UPS in Bypass Mode

In Bypass Mode, the output of the system is provided with three-phase AC power directly from the system input. While in this mode, the output of the system is not protected from voltage or frequency fluctuations or power outages from the source. Some power line filtering and transient protection is provided to the load but no active power conditioning or battery support is available to the output of the system in the Bypass Mode of operation.



The static bypass is comprised of a solid-state, silicon-controlled rectifier (SCR) static switch (SSW) and a backfeed protection isolation device K5. The static switch is rated as a continuous-duty device that is used anytime the inverter is unable to support the applied load. The static switch is wired in series with the backfeed protection. The static switch, being an electronically-controlled device, can be turned on immediately to pick up the load from the inverter without interruption. The backfeed protection is normally always closed, ready to support the static switch unless the bypass input source becomes unavailable.

2.3. UPS Features

The Santak UPS has many features that provide cost-effective and consistently reliable power protection. The feature descriptions provide a brief overview of the UPS standard features.

2.3.1. Advanced Battery Management

Advanced Battery Management technology uses sophisticated sensing circuitry and a three-stage charging technique that extends the useful service life of UPS batteries while optimizing the battery recharge time. ABM also protects batteries from damage caused by high current charging and inverter ripple currents. Charging at high currents can overheat and damage batteries.

In charge mode, the batteries are recharged. Charging lasts only as long as it takes to bring the battery system up to a predetermined float level. Once this level is reached, the UPS battery charger enters float stage and the charger is operating in constant voltage mode.

Rest mode begins at the end of charge mode; that is, after 48 hours of float charging (customer adjustable). In Rest mode, the battery charger is completely turned off. The battery system receives no charge current during this rest period of about 28 days (customer adjustable). During Rest mode, the open circuit battery voltage is monitored constantly, and battery charging is resumed when necessary.

2.3.2. Hot Sync

Hot Sync technology is an algorithm that eliminates the single point of failure in a parallel system and therefore enhances the system reliability.

3C3 HD series UPS external parallel system adopts thermal synchronization technology.

Hot Sync technology enables all uninterruptible power (UPS) to operate independently in a parallel system.

Hot Sync technology combines digital signal processing and an advanced control algorithm to provide automatic load sharing and selective tripping in a parallel UPS system. The load share control algorithms maintain synchronization and load balance by constantly making minute adjustments to variations in the output power requirements. The modules conform to demand and are not in conflict with each other for the load. Hot Sync systems are capable of paralleling for both redundancy and capacity.

2.4. Software and Connectivity Features

2.4.1. Customer Interface

Mini-Slot Communication Bays — there are three communication bays for mini-slot connectivity cards.

Mini-slot cards are quickly installed and are hot-pluggable. See [Chapter 5](#) for additional information.

2.4.2. Power Management Software

Intelligent Power software products offer tools for monitoring and managing power devices across the network. See [Chapter 5 COMMUNICATION INTERFACES](#) for more information.

2.5. Options and Accessories

Contact an Santak sales representative for information about the available options.

2.5.1. External Battery Cabinet (EBC)

Battery backup protection is provided by equipping the UPS system with multi external Battery Cabinets (EBC) containing Valve Regulated Lead Acid Battery (VRLA) batteries. The EBC is enclosed in its own separate cabinet, can be installed line-up-and-match with UPS cabinet.

2.5.2. Santak Sync Control (Sync Control)

The Santak Sync Control maintains critical load synchronization of either two separate single Santak UPS systems or two separate single Santak UPS systems. Synchronization of the UPS systems facilitates the uninterrupted transfer of customer loads from one load bus to another by means of downstream, dual source, solid state transfer switches. Enable the automatic synchronization action of the Santak Sync Control by pressing the Load Sync Enable pushbutton on the front of the panel. When enabled, the Load Sync Enable pushbutton illuminates.

The Santak Sync Control panel provides a three phase synchronization reference to each system. Each system uses this reference to regulate the inverter phase relationship so that the two system outputs can maintain synchronization with each other. To establish the three phase synchronization reference, each system provides bypass sensing voltage and output (critical load) bus voltage to the Santak Sync Control box.

For details, see [4.7.4](#) and [Table 4-3](#).

2.6. Battery System

The battery system provides emergency short-term backup power to safeguard operation during



brownouts, blackouts, and other power interruptions. By default, UPS is configured to use VRLA batteries. 3C3 HD also compatible with Santak certified third-party lithium-ion battery. Contact sales support to get the list of the compatible lithium battery list. Should there be a need to connect other type of batteries or other energy storage means, a certified service technician should be consulted prior to proceeding with installation.

The 3C3 HD UPS can be equipped with an external battery, and no internal batteries are available. For detailed battery specifications, see [Chapter 8](#).

2.7. Basic System Configurations

UPS Power Rating

The power rating of a single UPS is determined by the number of UPM, but the maximum power could not exceed the static bypass rating.

The UPS frames can be connected in parallel to create even larger systems. A maximum of four UPS frames can be connected in parallel. Above four UPS in parallel requirement can ask help from Santak technical solution team to customization design.

UPS Internal Options

The following table shows different standard and optional UPS options and the models where they apply.

Table 2-1: Standard and Optional UPS Options

	400 kW	500 kW	600 kW
Smart touch screen display for system control and monitoring	Standard	Standard	Standard
SNMP web interface (See Section 5.1)	Option	Option	Option
Internal MBS*	Option	Option	Option
Rectifier input switch*			
UPS output switch*			
Bypass switch*			
Integrated backfeed protection(K5)*	Option	Option	Option
Top Exhaust Accessory*	Option	Option	Option
Single Input	Option	Option	Option
Dual Input	Standard	Standard	Standard
3-Wire/4-Wire*	Option	Option	Option
Air filter	Standard	Standard	Standard

*: Need to be assembled in the factory.

Additional options and accessories are also available. These include different software and connectivity options and external switchgear and power distribution options.

Chapter 3 UPS INSTALLATION PLAN AND UNPACKING

Use the following basic sequence of steps to install the UPS:

1. Create an installation plan for the UPS system
2. Prepare your site for the UPS system
3. Inspect and unpack the UPS cabinet
4. Unload and install the UPS cabinet, and wire the system
5. Complete the installation checklist ([Chapter 10](#))
6. Have authorized service personnel perform preliminary operational checks and startup.



NOTE

Startup and operational checks must be performed by an authorized Santak Customer Service Engineer, or the warranty terms specified in [Chapter 9](#) become void. This service is offered as part of the sales contract for the UPS. Contact service in advance (usually a two-week notice is required) to reserve a preferred startup date.

3.1. Creating an Installation Plan

Before installing the UPS system, read and understand how these instructions apply to the system being installed. Use the procedures and illustrations in [Section 3.2](#) and [Chapter 4](#) to create a logical plan for installing the system.

3.2. Site Preparations

For the UPS system to operate at peak efficiency, the installation site should meet the environmental parameters outlined in these instructions. If the UPS needs to be operated at an altitude higher than 1000 m, contact your service representative for important information about high altitude operation. The operating environment must meet the weight, clearance, and environmental requirements specified.

3.2.1. Environmental and Installation Considerations

The UPS system can be installed where there is TN or TT power distribution system.

The environmental requirements specified below are for the air at the intake ports and are the maximum, not to exceed, ratings:

- There shall be at least a 1.0°C (1.8°F) difference between the dry bulb temperature and the wet bulb temperature, at all times, to maintain a non-condensing environment.
- The maximum rate of temperature change shall be limited to 3°F over 5 minutes (36°F/hour), based on the ASHRAE Standard 90.1-2013.

Cautions regarding UPS operating environmental conditions:



The newer, more energy efficient data center cooling methods (such as air side economization) can create much wider ranges of temperature and Relative Humidity (RH) in the UPS room and/or data center.

There are two aspects of this increased operating environment that can, if ignored, create issues:

- One is the creation of microclimates, which are persistent variations of temperature and/or RH within a single room; for example one side of the room is always cooler than the other side, no matter what the actual temperature is.
- The other aspect is the rate of change of temperature and/or RH, which can occur during transitions within the cooling system. Examples: changing the mixture ratio of inside versus outside air, or external changes in the outside air when going from nighttime into day, and back to night.

When ignored, either one of these aspects can create an undesirable microclimate at the UPS location. If the environment created by this microclimate exceeds the Santak UPS operating specification, the UPS reliability, over time, will be reduced. These same environmental extremes will also create reliability concerns for any servers that are exposed to them.

The UPS system installation must meet the following guidelines:

- The system must be installed on a level floor suitable for computer or electronic equipment. The floor must be suitable for heavy weight and wheeling.
- The system must be installed in a temperature and humidity controlled indoor area free of conductive contaminants.
- The cabinet can be installed in line-up-and-match or standalone configurations.

The UPS equipment operating environment must meet the weight requirements shown in [Table 3-1](#).

Table 3-1: Dimensions and Weights

	Shipping dimensions (WxDxH)	Cabinet dimensions (WxDxH)WxDxH)	Shipping weight	Installed weight
400kW	1290 x 1120 x 2162 mm	1100 x 1000 x 2000 mm	770kg	650kg
500kW	1290 x 1120 x 2162 mm	1100 x 1000 x 2000 mm	820kg	700kg
600kW	1290 x 1120 x 2162 mm	1100 x 1000 x 2000 mm	940kg	820kg

*:The dimension and weight of a single top exhaust accessory.

The UPS cabinets use forced air cooling to regulate internal component temperature. You must allow clearance in front of and behind each cabinet for proper air circulation.

The clearances required around the UPS cabinet in both of these situations are shown in [Table 3-2](#).

Table 3-2: UPS Cabinet Minimum Clearances

	Exhaust Clearance
From Top of Cabinet D1	300 mm
From Front of Cabinet D2	1000 mm
From Back of Cabinet D3	800 mm*

* Cabling may require more space.

The picture takes a 600kW cabinet as an example

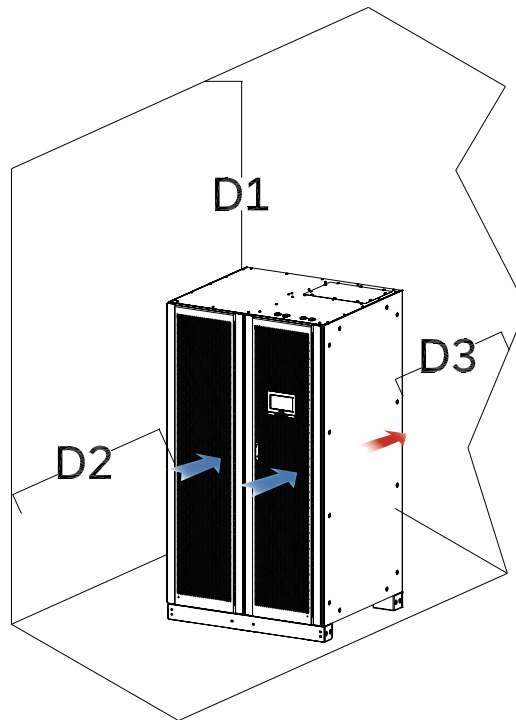

Figure 3-1: UPS Cabinet Clearances. See [Table 3-2](#).



The basic environmental requirements for operation of the UPS system are:

- Ambient Temperature Range: from +0°C to +30°C, To ensure that your UPS functions well, please operate it in an environment with an ambient temperature ranging between 0 - 30°C. If the ambient temperature exceeds 30°C, the UPS should be de-rated by 12% for every increase of 5°C in the temperature; the maximum ambient temperature should not exceed 50°C as UPS operating with loads in high-temperature environments for a long time will result in the reduction of the battery life. For example, if the UPS working environment temperature is 35°C, the load must be less than 88%. If it exceeds 90%, the UPM will shut down.
- Recommended Operating Range: from +20°C to +25°C
- Maximum Relative Humidity: 95%, non condensing

The room where the UPS is placed must meet the following air circulation requirements:

- For 400KWUPS, air flow need be not lower than 3600M³/h;
- For 500KWUPS, air flow need be not lower than 5700M³/h;
- For 600KWUPS, air flow need be not lower than 6800M³/h;

The UPS ventilation requirements are shown in the following table:

Table 3-3: Air conditioning or Ventilation Requirements During Full Load Operation

Rating	Heat Rejection (Kcal/hour)	power loss(W)	Heat Rejection (BTU/h x 1000)
400kW	14331	16667	56.9
500kW	17914	20834	71.1
600kW	21496	25000	85.3

Dimensions are in millimetres

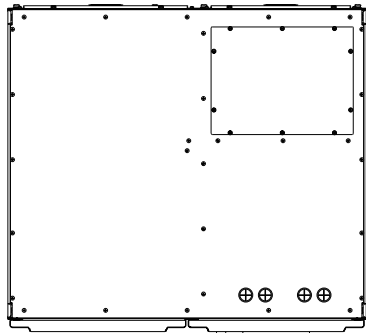

Top View

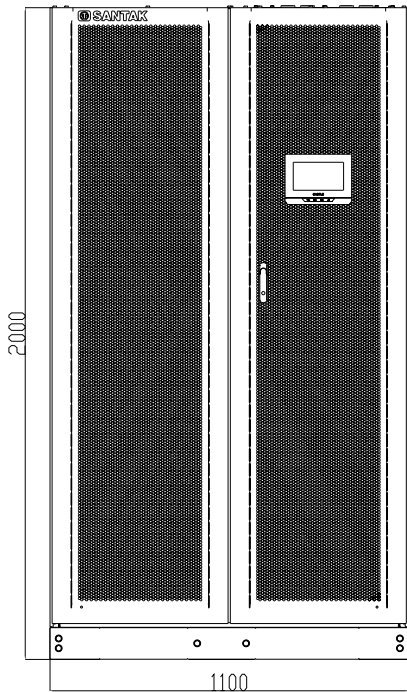

Front View

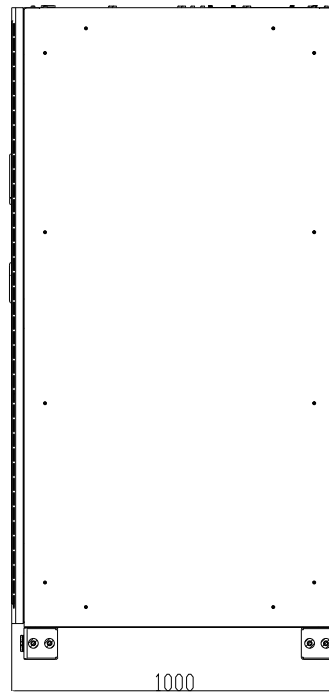

Right View

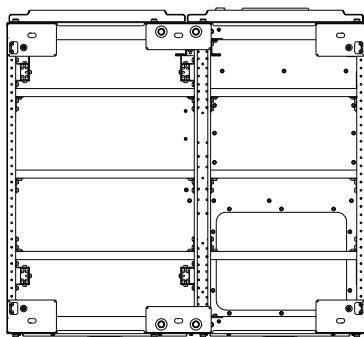

Bottom View

Figure 3-2: UPS Dimensions

Dimensions are in millimetres

Dimensions are in millimetresDimensions are in millimetresDimensions are in millimetres



3.2.2. UPS System Power Wiring Preparation



NOTE

If installing a maintenance bypass, a minimum of two separate feeds with upstream feeder breakers, or a single feed with two upstream feeder breakers, must be provided: one for the UPS or rectifier input breaker (if installed) and one for the maintenance bypass input. DO NOT use a single feed or a single feeder breaker to supply both the UPS or rectifier input breaker and the maintenance bypass. If a bypass input breaker is installed in the maintenance bypass and a single-feed UPS is being installed, a single feed to the maintenance bypass is acceptable for supplying both the UPS and the bypass.

Read and understand the following notes while planning and performing the installation:

- Refer to national and local electrical codes for acceptable external wiring practices.
- To allow for future kVA upgrades (software and/or hardware), consider using conductors sized for full bypass rating of the UPS.
- Material and labor for external wiring requirements are to be provided by designated personnel.
- For external wiring, use 90°C copper wire. See the appropriate information in [Table 3-8](#). Wire sizes are based on using the specified breakers.
- If wire is run in an ambient temperature greater than 30°C, higher temperature wire and/or larger size wire may be necessary.
- Specification is for copper wire with a 90°C rating.

4-wire system:

- The input uses three live wires and N wires, plus a grounding wire (protective grounding conductor).the phases must be symmetrical about ground (from Y-type/Wye source) for proper equipment operation.
- Support the load that needs to take N wire.
- If the neutral wire is disconnected, all phase wires should be disconnected at the same time.

3-wire system:

- The input uses three live wires and grounding wires (protective grounding conductors).
- Without the N-line, it does not support the load that requires the N-line.

The selection of wire diameter needs to take into account the future power upgrade of UPS.

Table 3-8: Maximum Recommended Multi-core Cable Sizes (unit:mm²)

power	UPS input	UPS output	Bypass input	N*	Battery*	PE*
400kW	3*150	3*150	3*150	5*150	5*150	8*150
500kW	3*150	3*150	3*150	5*150	5*150	8*150
600kW	3*240	3*240	3*240	5*240	4*240	6*240

*:The UPS busbars wiring needs to be evenly divided (see [Figure 4-9](#) to [Figure 4-15](#) for the location of the busbars). The selection of wire diameter needs to take into account the future power upgrade of UPS.

Table 3-9: Minimum Recommended Multi-core Cable Sizes (unit:mm²)

power	UPS input	UPS output	Bypass input	N*	Battery*	PE*
400kW	3*70	3*70	2*70	4*70	4*70	6*70
500kW	3*70	3*70	3*70	4*70	4*70	6*70
600kW	3*95	3*95	3*95	4*95	5*95	6*95

*:The UPS busbars wiring needs to be evenly divided (see [Figure 4-9](#) to [Figure 4-15](#) for the location of the busbars).

Table 3-10: Rated and Maximum Currents for Rated Power and Voltage (unit:A)

power	Input Current			Output current			Battery (Rated)	Battery (Max)
	380	400	415	380	400	415		
400kW	665	631	609	638	606	584	911	1094
500kW	791	752	725	760	722	696	1085	1302
600kW	950	905	870	915	870	835	1302	1563



NOTE

Bypass fuse type should be greater than 10 times rated I²t 20ms.



See the following table for power cable terminations.

Table 3-11: UPS Power Cable Terminations

Terminal Function	Terminal	Function	400/500k		600k	
			Bolt Specifications	Tightening-torque (unit: Nm)	Bolt Specifications	Tightening-torque (unit: Nm)
AC input to UPS rectifier	MAINS INPUT	L1,L2,L3,N	M10/M12	42/76	M12	76
AC input to bypass	BYPASS INPUT	L1,L2,L3,N	M10/M12	42/76	M12	76
UPS output	OUTPUT	L1,L2,L3,N	M10/M12	42/76	M12	76
DC input from external battery to UPS	BAT	Battery+ Battery-	M10/M12	42/76	M12	76
Protective earth	PE	PE	M10/M12	42/76	M12	76



NOTE

External overcurrent protection is not provided by this product, but is required by codes. Refer to [Table 3-9](#) for wiring requirements. If an output lockable disconnect is required, it is to be supplied by the user.



CAUTION

To reduce the risk of fire, connect only to a circuit provided with maximum input circuit breaker current ratings from [Table 3-10](#) in accordance with the national and local installation rules.

The line-to-line unbalanced output capability of the UPS is limited only by the full load per phase current values for AC output to critical load shown in [Table 3-10](#). The recommended line-to-line load unbalance is 50% or less.

Source Protection for the AC Input to Bypass should suit the characteristics of the load and take account of effects such as Inrush or Starting Current. Bypass and output overcurrent protection and bypass and output disconnect switches are to be provided by the user.

For UPS wiring diagrams, see Section [2.1](#) Looking inside the UPS system.

3.2.3. UPS System Interface Wiring Preparation

Control wiring for features and options should be connected at the customer interface terminal blocks located on top front of the UPS, behind the door.



DANGER

Do not directly connect relay contacts to the mains related circuits. Reinforced insulation to the mains is required.

Read and understand the following notes while planning and performing the installation:

- All interface wiring is to be provided by the customer.
- When installing internal interface wiring to Mini-slot terminals, route the wiring through the internal opening in the Mini-slot communication bay.
- All signal inputs or remote features require an isolated normally-open contact or switch (rated at 24 Vdc, 20 mA minimum) connected between the alarm input and common terminal. All control wiring and relay and switch contacts are customer-supplied. Use twisted-pair wires for each alarm input and common.
- The signal inputs can be programmed to display the alarm functional name.
- LAN and telephone drops for use with Mini-slot cards must be provided by facility planners or the customer.
- The UPS Battery Aux and 48 Vdc Shunt release signal wiring from the UPS to the DC source disconnect device is optional.
- Battery Aux and 48 Vdc Shunt release wiring should be a minimum of 1.5 mm².
- The Remote EPO feature opens all switchgear in the UPS cabinet and isolates power from your critical load. Local electrical codes may also require tripping upstream protective devices to the UPS.
- The Remote EPO switch must be a dedicated switch not tied to any other circuits.
- A jumper wire must be connected between pins 1 and 2 on connector EPO, if the normallyclosed (NC) remote EPO contact is used.
- Remote EPO wiring should be a minimum of 0.75 mm² and a maximum of 2.5 mm².
- The maximum distance between the Remote EPO and the UPS cannot exceed 150 meters.
- Alarm relay contacts have a maximum current rating of 5 A and a switched voltage rating of 30 Vac (RMS) and 30 Vdc.
- Alarm relay wiring should be a minimum of 0.75 mm².



Chapter 4 UPS SYSTEM INSTALLATION

The customer has to supply the wiring to connect the UPS to the local power source. The electrical installation procedure is described in the following section. The installation inspection and the initial start-up of the UPS and installing an extra battery cabinet must be carried out by qualified service personnel such as a licensed service engineer from the manufacturer or from an agent authorized by the manufacturer.

4.1. Preliminary Installation Information



WARNING

Physical injury or death may follow, or damage may occur to the UPS or the load equipment if these instructions are ignored.

Refer to the following while installing the UPS system:

- Chapter 3 for cabinet dimensions, equipment weight, wiring and terminal data, and installation notes.
- Do not tilt the cabinets more than $\pm 10^\circ$ during installation.
- If perforated floor tiles are required for ventilation, place them in front of the UPS.
- The UPS unit is not suitable for IT or corner-earthed power distribution systems.
- Suitable for mounting non-combustible surfaces only

4.2. Inspecting and Unpacking the UPS Cabinets



NOTE

- **The UPS cabinet is heavy. If unpacking instructions are not closely followed, the cabinet may tip and cause serious injury.**
- **Do not stand directly in front of the pallet while unloading the cabinet. If unloading instructions are not closely followed, the cabinet may cause serious injury.**

1. Carefully inspect the outer packaging for evidence of damage during transit



NOTE

Make a visual inspection and check that there are no signs of shipping damages. The 'Drop&Tell' indicator on the rear side of the unit shall be intact if the equipment has been handled properly.

2. Use a forklift or pallet jack to move the packaged cabinet to the installation site, or as close as possible, before unpacking. If possible, move the cabinets using the pallet. Insert the forklift or pallet jack forks between the supports on the bottom of the pallet.



NOTE

- For the following steps, verify that the forklift or pallet jack is rated to handle the weight of the cabinet (see [Table 3-1 Dimensions and Weights](#)).
 - Do not tilt the UPS cabinets more than 10° from vertical or the cabinets may tip over.
-
3. Use a hammer to pry open the metal connection components around the wooden box, remove the wooden box, cushioning materials and moisture-proof bag ([Figure 4-1 ~ Figure 4-3](#)).
 4. Remove the front and rear foot baffles at the bottom and save them, remove the anchor screws, and then put the foot baffles back ([Figure 4-4](#))
 5. Insert the fork into the bottom of cabinet from the side ([Figure 4-5](#)).
-



NOTE

To prevent damage to the wiring channel and wiring in the UPS cabinet base when lifting or moving the cabinet:

- Lift and move the cabinet using only the front or rear forklift slots.
- Verify that the forklift forks are in a horizontal position before inserting them into the forklift slots. DO NOT angle fork tips upward.
- Insert the forks all the way through the base. DO NOT insert forks partially into the base to move the cabinet.
- Forks may be partially inserted into the front or rear forklift slots for minor positioning if the forks are kept in a horizontal position with no upward angling.
- DO NOT use the forklift slots on the end of the cabinet to move the cabinet.
- End forklift slots may be used for minor positioning if the forks are kept in a horizontal position with no upward angling.

If these instructions are not followed, damage to the wiring channel and wiring will occur.

6. Using the forklift, move the UPS cabinet to the final installed location.
 7. Install the UPS system. Please follow [Section 4.3](#).
-



NOTE

While waiting for installation, protect the unpacked cabinet from moisture, dust, and other harmful contaminants. Failure to store and protect the UPS properly may void your warranty.

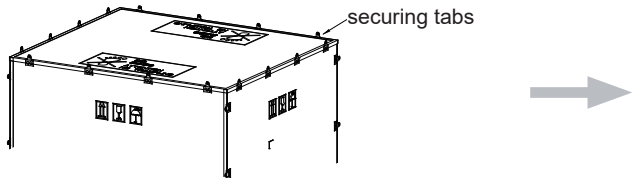

Figure 4-1: Straighten the Securing Tabs

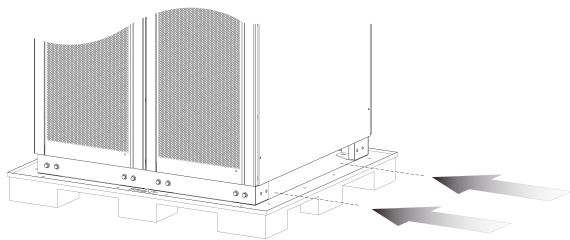

Figure 4-5: Fork into Position

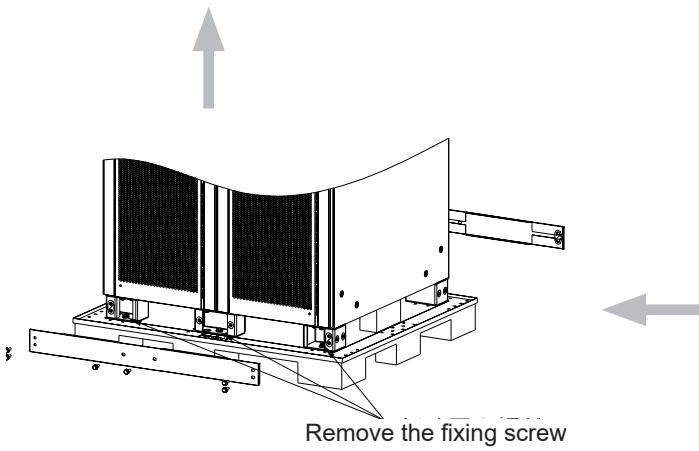

Figure 4-4: Remove the fixing screw

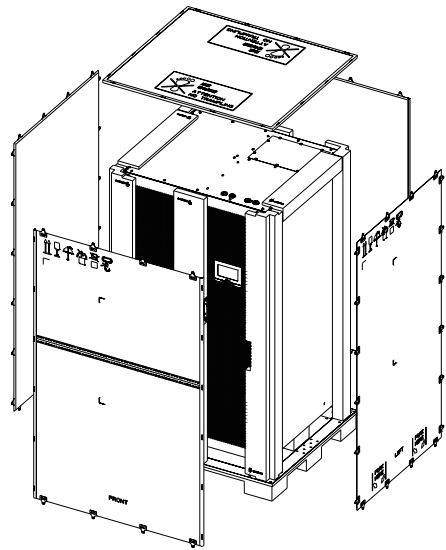

Figure 4-2: Remove Wooden Box

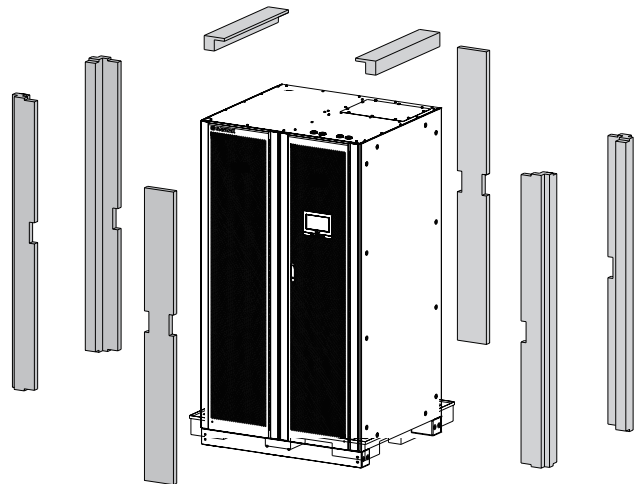

Figure 4-3: Remove Cushioning

4.3. UPS System Installation

4.3.1. Mechanically joining the Cabinet Sections



NOTE

- For the following steps, verify that the forklift or pallet jack is rated to handle the weight of the cabinet (see [Table 3-1 Dimensions and Weights](#)).
 - Do not tilt the UPS cabinets more than 10° from vertical or the cabinets may tip over.
-

1. Remove the front and rear baffle Plates of the UPS cabinets. Please keep the baffle Plates and screws for later use;
See [Figure 2-3](#) for the location of the baffle Plates;
2. Use the holes on the feet. Place the UPS cabinets on the ground or channel steel;
See [Figure 3-2](#) and [Figure 3-5](#) bottom view for hole dimensions, For more detailed installation drawings, please contact customer service to provide;
3. Fix the cabinet foot to the floor or channel steel, reinstall the baffle Plates, and use the M10*25 bolt (16pc)/M10 spring washer (16pc)/M10 large flat washer (16pc) removed in step 1 to fix it. Torque: 28 Nm;
4. If installing a parallel system, repeat the above steps to all units in the system;
5. Proceed to Section [4.3.2](#).



4.3.2. Routing Cables

3C3 HD UPS can support top and bottom cable entry. The customer power wires and control wiring can pass through openings on the top rear of UPS cabinet connect to UPS terminal blocks at rear of UPS, see [Figure 4-6](#) and [Figure 4-12](#).

1. Open the rear cover of the IO cabinet.
2. Remove the bottom or top cable entry cover, Drill holes according to wire AWG size, Stick the wire protection loom around the hole to protect the wire, Reattach the cover to the cabinet in the end.
3. For the cable installed from top, arrange the cable from the top cable channel, the cable passes through the top entry cover, and connect the to the bus bars from top to bottom in order of input, bypass, battery, output, ground cable.

For the system installed from bottom, arrange the cable from the bottom cable channel, the cable passes through the bottom entry cover, and connect to the bus bars from bottom to top in order of the ground, output, battery, bypass, input cable etc.

4. Arrange the cables and fix the cables to the cable management bracket in an orderly manner. And use fireproof mud to seal the gap between the cable and the entry cover.
5. Clean the residual debris in the cabinet and install the rear cover of the IO cabinet,
6. If installing a parallel system, repeat the above steps to all units in the system.
7. Proceed to Section [4.4](#).



WARNING

Custom should take care to arrange cables to left and right sides of cabinet when doing wiring, avoid blocking the rear vent of UPM.

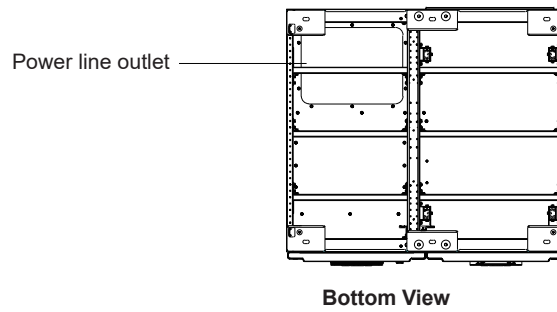
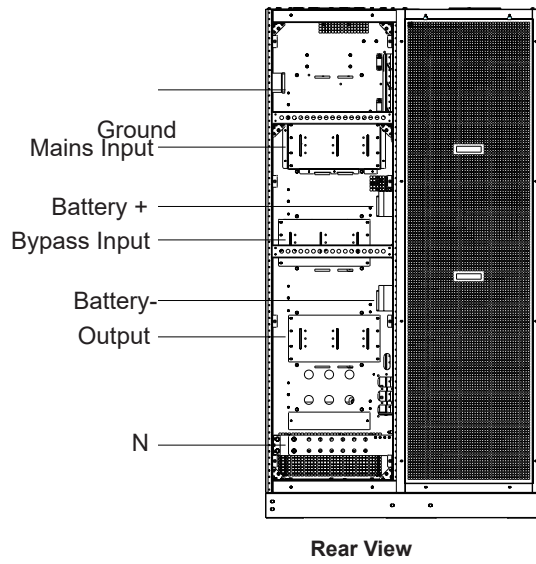
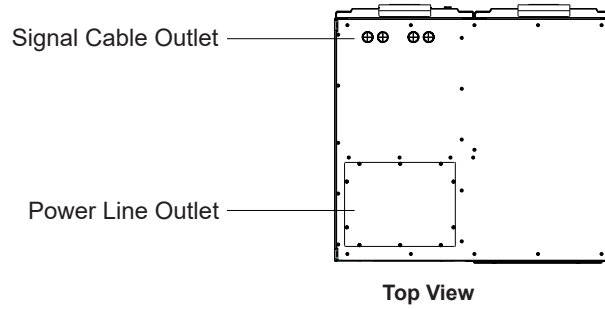

Figure 4-6: Gland Plate and Connector Locations



4.4. Battery System Installation

External Battery Cabinet Installation (EBC)

Before connecting the external battery, please read the notice and warning label on the battery cabinet.



WARNING

- In the event of malfunction, the battery cabinet chassis or battery cabinet frames may become live!
- Special care should be taken when working with the battery cabinet associated with the equipment. Ensure the battery number is suited to the setting of the battery charging voltage before installing the battery. When the battery cabinet is connected the overall voltage exceeds nominal voltage. It is very important to ensure that the batteries are installed separately, in a dedicated battery cabinet.
- Battery back-up time do not exceed one hour, if the battery setting shall be exceeded one hour, consult to the professional personnel.



NOTE

- The most common battery type used in UPS installations is the valve regulated battery. Valve regulated cells are not sealed. The amount of gas given off is less than for flooded cells, but when planning the battery installation, allowance must be made for adequate ventilation and heat dissipation. Valve regulated cells are not completely maintenance-free. They must be kept clean and their connections checked periodically to ensure they are tight, and that there is no evidence of corrosion. It is inevitable that the batteries will lose charge during transportation and storage; before attempting to carry out an autonomy test, ensure that the batteries are fully charged as this may take several hours. Cell performance typically improves after a few discharge/recharge cycles.
- The requirements of the EC directives are satisfied when battery cabinet are used with original accessories. If alternative batteries are used, you must ensure that the applicable EC directives are met and declare conformity.

The default battery settings of the UPS are for 12 Vdc VRLA batteries. If requested to use other battery types, contact your Santak representative. For the battery specification, see Section [8.4 Battery Specification](#).

Connect the battery cabinet as follows:

1. Turn off the UPS.
2. Check all the external battery breakers are open.
3. Connect PE first.
4. Connect the battery cabinet(s) with cables sized according to cable cross section and protective device specification to terminals + (positive pole) and - (negative pole).
5. Refer to instructions provided with the battery cabinet or by vendor.



WARNING

ENSURE CORRECT POLARITY!

4.4.1. Supported Battery Configuration

Santak 3C3 HD UPS support common or separate battery configurations among frames. The flexible battery setting will benefit the customer to save cost or optimize site planning design.

For separate battery configuration, each 3C3 HD frame connect to separate battery bank. And the battery settings between frames could be different but the backup time of whole UPS system is limited by the minimum battery bank (See [Figure 4-7](#) and [Figure 4-17](#)).

For common battery configuration, now support 2/3/4 frames paralleled and connect to a common battery bank. For common battery configuration. Charging and discharging batteries are shared evenly among the UPMs. And there is no limitation how to allocate UPM among the frames. Which means each frame may contain different numbers of UPM. But charging and discharging power is equal for all UPMs.

It is recommended using separate battery breaker with auxiliary contactor even for common battery and each battery breaker's aux is connected to the own frames' TB (See [Figure 4-7](#) and [Figure 4-17](#)).

Support various DC source including VRLA, Lithium-ion, Ni-Cad, Supercaps and flywheel. For Lithium-ion battery application, battery BTR and detail information shall refer to the battery's own BMS. Or you can contact Santak for more integration application of BMS data on UPS's HMI.

4.4.2. Installing the Lithium Battery Cabinet

3C3 HD UPS support full-link and 365x24 communicate with Lithium Battery' BMS (Modbus plus dry contact). Make it more safer, more reliable and more efficiency for lithium battery application. Eaton UPS using specific Modbus protocol to monitor and retrieve critical information from BMS. Such as SOC (State of Charge), SOH (State of Healthy), battery cell voltage and temperature, system current and system warning and status information etc. UPS is monitoring and processing lithium battery 365x24 without interruption. UPS also combine with real time load power meters to convert accurate battery time remain (BTR) to display on HMI. Especially UPS is capable to adjust the charging current based on lithium battery temperature and status actively, and turn off the charger when demand or abnormal circumstance once detect. Users can also browse the critical battery information and status on battery screen from HMI.(See [Figure 6-19](#) and [Figure 6-20](#)).

UPS is capable battery energy storage with full-link communication. Users has optional to upgrade the UPS energy aware kits to utilize Time of Use and peak shaving BESS application. Eaton UPS can protect the critical load without comprise and also fully mining the value of lithium battery. Regarding to 93PR UPS BESS feature, please contact with Eaton for



more details.

Now supporting to connect the UPS specific BMS protocol port to the lithium Battery Modbus port. First support CATL Lithium battery model. More models will be supported in the future

Currently, it is connected to the Modbus port of the lithium battery through the dedicated lithium battery BMS protocol port of the UPS. First support CATL lithium battery system of CATL, and then support more lithium battery systems in succession

3C3 HD 400~600kVA UPS provides 2 kinds of RS485 port (Modbus protocol) connection methods to connect to the lithium battery cabinet. The UPS side can choose the TB terminal interface (See Cabinet PIN Corner Definition) ([Figure 5-1](#)) or the RJ45 interface ([Figure 5-1](#)) (485A PIN7, 485B PIN8) connection, these two connection methods are 2 to 1. As a Modbus communication master, the UPS is one-to-one connected to the main cabinet (Modbus slave) of the lithium battery system.

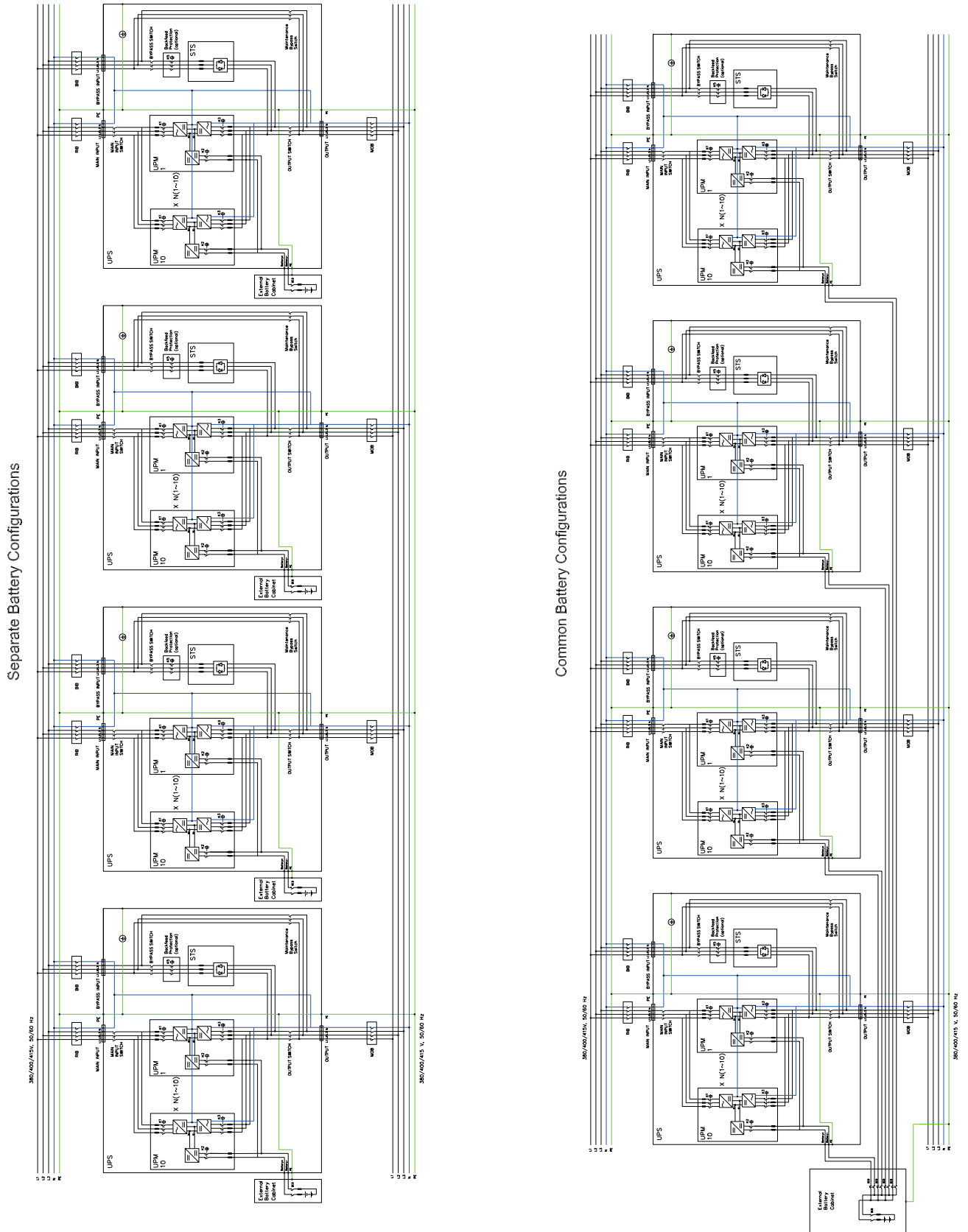

Figure 4-7: Separate Battery Configurations and Common Battery Configurations



4.5. Installing a Remote EPO Switch

A remote EPO switch can be used in an emergency to shut down the UPS and remove power to the critical load from a location away from where the UPS is installed.

EPO is to be connected to the UPS's top front panel, on connector EPO. Below are the NO and NC connections of the EPO switch.

Table 4-1: Normally-Open REPO Connections and Wire Terminations

From REPO Station Switch Contact Block (Either Block)	UPS REPO Terminal	Name	Description	Recommended Minimum Wire Size	Size of Wire Termination	Tightening Torque
3 NO	3	EPO_A	Input: Normally-open dry contact used to activate UPS EPO from a remote switch	Twisted Pair Wires #18 AWG	#16-#30 AWG	2 lb in (0.22-0.25 Nm)
4 NO	4	EPO_B				

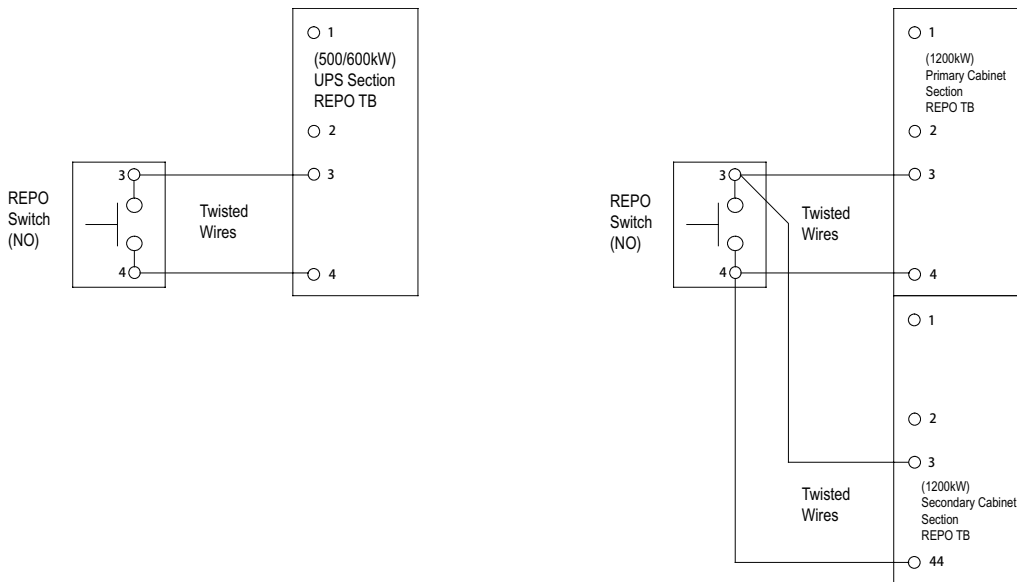

Figure 4-8: Normally-Open REPO Switch Wiring



NOTE

The REPO switch must be a latching-type switch not tied to any other circuits.

Table 4-2: Normally-Closed REPO Connections and Wire Terminations

From REPO Station Switch Contact Block (Either Block)	UPS REPO Terminal	Name	Description	Recommended Minimum Wire Size	Size of Wire Termination	Tightening Torque
1 NC	1	EPO_A_B	Input: Normally-closed dry contact used to activate UPS EPO from a remote switch	Twisted Pair Wires #18 AWG	#16-#30 AWG	2 lb in (0.22-0.25 Nm)
2 NC	2	GNDISO				

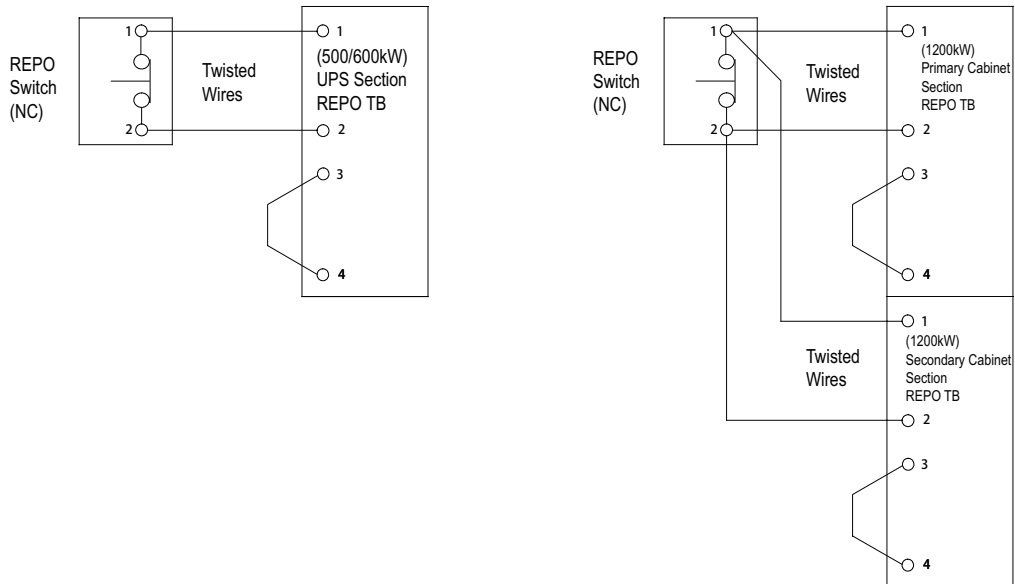

Figure 4-9: Normally-Closed REPO Switch Wiring



NOTE

The REPO switch must be a latching-type switch not tied to any other circuits.



4.6. Installing Interface Connections

3C3 HD UPS contains a total of five (5) signal input connectors for customers which can be used for giving remote control commands to the UPS. Customer interface connector CN5 can be used for these purposes. Each input is a dry relay contact input and requires two wire signaling. None of the inputs are

pre-programmed but need to be separately programmed by qualified service personnel.

When using an external battery system (either the original 3C3 HD battery cabinet or a customer sourced battery cabinet/rack), external signaling wiring is recommended to be connected.

One (1) general alarm relay output is also on the front panel. This output is either normally open (NO) or normally closed (NC). Polarity selection is made with wiring connection.

By default, the general alarm relay activates when a system alarm is active, that is, any ALARM condition in the system is active. Alternatively, it can be activated with any particular event but this must be programmed separately by qualified service personnel. The alarm relay is designed for signal level (ELV or SELV) voltages only, not for utility use. For higher signaling circuit voltage requirements, please use Industrial Relay Adapter in Mini-slot.

4.6.1. Installing Customer Input Signals Interface

These inputs are located see [Figure 5-1 Communication Interfaces](#). Tie points with strain relief for communication cables are located on the right and left side of the cable conduit.

Signal inputs can be configured to different functions. Normally these functions are either informative (for example "On Generator") or functional (for example remote "Go to bypass" command).

4.6.2. External Battery Breaker Wiring Interface

When using the original battery cabinet from the Santak, the battery breaker interface wiring is provided with the cabinet. Connecting it requires only routing the wires from the cabinet to the bottom section of the UPS.

When using third party battery system, the breaker must be equipped with auxiliary signal and should have a 48V Shunt release for remote opening of the breaker, when needed.

Wire entry for battery breaker signal wiring is located on the top of the UPS cabinet. The wire can pass through the top of UPS cabinet and locked to external battery breaker control terminal at the front of the module (see [Figure 5-1](#)). Pin 1 and 2 of the terminal are for signal connection of battery breaker Shunt release control, and Pin 3 and 4 are for Signal connection of battery breaker Aux contact detection.

4.6.3. Relay Output Interface Connections

The general alarm relay is a dry relay signal output. The relay can be used for informing the operators about UPS alarm conditions, for example through a building management system. By default, the relay is configured to activate when the UPS general alarm is active, that is, any event having ALARM status is active. The relay can also be configured to activate by some other event but this needs to be done by authorized service.

Relay signal wiring can be installed only through the signal cabling canal, from back to front, on the top section of the UPS.

Table 4-3: Dry Contact Output Terminal

User logical selection	Terminal pins connection shows on HMI	Note
NO	2-3	Pin1 disconnection
NC	1-3	Pin2 disconnection

4.6.4. Mini-slot Interface Connections

For Mini-slot accessories and communication devices selection see [Chapter 5 COMMUNICATION INTERFACES](#). For installation and setup of a Mini-slot card, please contact your Santak representative.

To install wiring to connections:

1. If not already installed, install the LAN and telephone drops.
2. Open the front door of the UPS.
3. Remove the particular Mini-slot cover plate by removing the two screws securing the plate and install the device by pushing it all the way in.
4. Secure the Mini-slot communication device with two screws.
5. Route and install the LAN, telephone, and other cables to the appropriate Mini-slot cards. Cable route is through the signal cable canal, on top section of the UPS.
6. Refer to the manual supplied with the Mini-slot card for operator instructions.
7. When all wiring is completed, close the front door and secure the latch.

4.6.5. Installing Signal Interface Connections In Parallel System

Installation of signal interface connections in parallel system is done by following the aforementioned instructions. Signal inputs can be paralleled between the units, that is, the same contact can be used for several units' signal input signaling. This concerns also the EPO-signal.



4.7. Wiring Parallel 3C3 HD UPS Systems

The outputs of multiple 3C3 HD UPS systems can be connected in parallel. A maximum of four 600kW UPS frames can be connected in parallel and a maximum of two 1200kW UPS frame can be connected in parallel. The UPS static bypass power rating needs to be identical among all paralleled units. However, paralleled UPS cabinets can be housed with different number of UPM power modules. Above four UPS in parallel requirement can ask help from Santak technical solution team to customization design.

The outputs are paralleled to increase the load capacity of the power system and for redundancy. The system is paralleled for (N+1) redundancy, as long as there is always one or more UPS online than required to support the load. The system is paralleled for capacity if all UPSs in a system are required to support the load.

Communication is required between the UPSs for system metering and mode control. System level communication and control are accomplished using a Controller Area Network (CAN). A pull-chain signal in each UPS, connected to the other UPSs in parallel and tied to the bypass Status Relay in each UPS, is used for a secondary communication path. This arrangement ensures bypass control even if the CAN bus is lost.



WARNING

Units with an internal MBS switch may not be connected in parallel.

4.7.1. Power Wiring Overview

Refer to Section [3.2.2 UPS System Power Wiring Preparation](#) for recommended cable and external fuse sizes and installation practices.

Input Feed

The Input feed is defined as the power source connected to the UPS rectifier. The feed to all UPS's inputs must be derived from the same source.

Bypass Feed

The Bypass feed is defined as the power source connected to the UPS Bypass. The feed to all UPS's bypass must be derived from the same source. The shortest length of power wire from the source to the UPS must be a minimum of 95% of the length of the longest wire.

Output

The neutrals of all UPSs must be connected. The shortest length of wire from the source to the UPS must be a minimum of 95% of the length of the longest wire. The measurement is with respect to where the UPS's outputs are tied.

Dual Source

The Input Feed and Bypass feed may be separate sources. The sources must share a common neutral.

Battery connection

A separate battery shall be connected to each UPS, and the battery capacity for each UPS must be identical. A common battery for all UPSs is not supported.

Parallel system wiring



CAUTION

- **Parallel system combined input and output cable length should be in accordance with the following rule. It should be designed to ensure that wiring impedance from point of supply to UPS input and from UPS output to load connection for each UPS module in a multi-module system is equal, or within a tolerance of approximately $\pm 10\%$. This is to ensure approximately equal current sharing when in static bypass mode and restrain input/output high frequency loop current of parallel system. Suggest that parallel system combined input and output cable length no less than 10m, 5m for input and 5m for output.**

Total length of 1A =2A=3A=4A

1B=2B=3B=4B

1C=2C=3C=4C

- **If installing only two UPS modules (redundant), this requirement is no longer required as each UPS is capable of supporting the full bypass requirement. However, this would preclude future expansion.**
 - **Ensure that each UPS static bypass is fed from a single common source, as is an external bypass switch if installed. If each UPS is fed with a separate rectifier source, please consult Santak for advice on compatibility.**
-

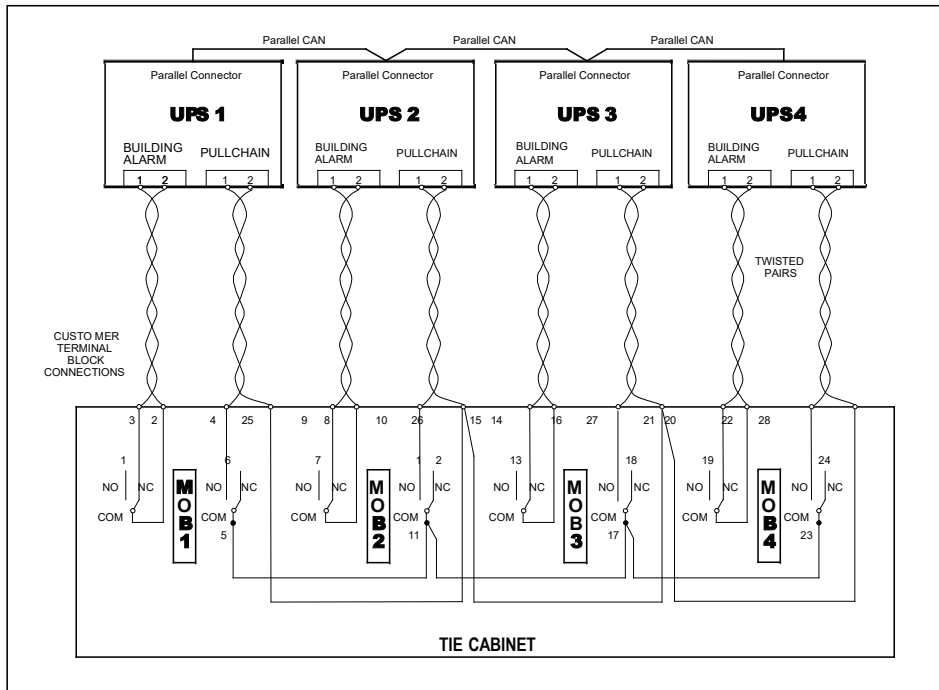

UPS paralleling wiring diagram – with parallel tie cabinet

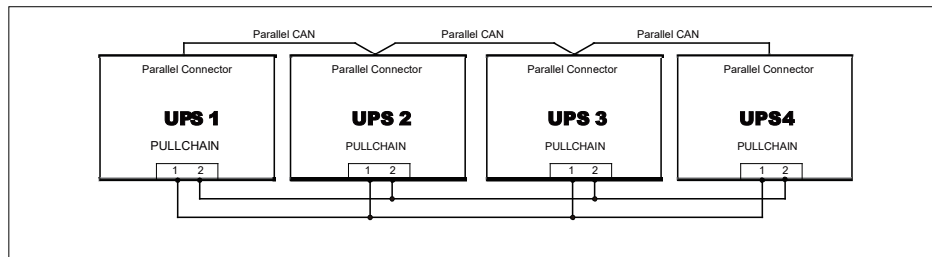

UPS paralleling wiring diagram – without parallel tie cabinet

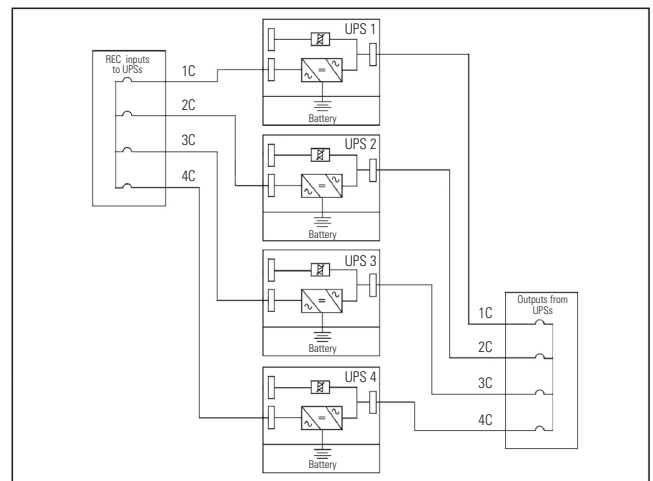
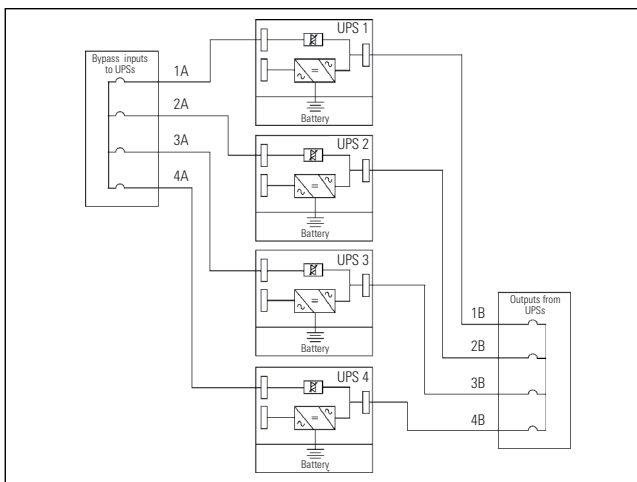

Parallel UPS system connections

Figure 4-10: Principle of Paralleled UPS Systems

4.7.2. Control Signals Overview

Two controls signals (External CAN Network, Bypass Pull-Chain) are required for external paralleling. Both of these control signals are fault tolerant and alarmed when disconnected.

External CAN (ECAN)

ECAN provides means for communications between the UPS's in a parallel system. The system will continue to share load and protect the load when this network fails.

Bypass Pull-Chain

Bypass Pull-Chain is an open collector signal that goes low when the Bypass static switch of any UPS is online. When External CAN (ECAN) is down, the pull-chain is low, and the UPS is online, the UPS will lock to and transfer to bypass. Service can manually short this signal in some rare failure modes to force a system transfer to bypass.

Signal Inputs Actions

Each UPS has maximum eight signal inputs, 5 native and one in each Mini-slot when using a suitable connectivity device. These inputs can be configured with action items. The following action items affect all UPSs in the system.

Wiring EPO switch in parallel

It is recommended to use separate EPO circuit for each parallel unit.

4.7.3. Installing Bypass Control Wiring

1. During the installation, follow all the safety instructions given in the 3C3 HD User's and Installation Guide.
2. 12-pin terminal block for external parallel control signals is accessible on the right side of the communication interface, on the top section of the UPS.
3. The Phoenix Contact

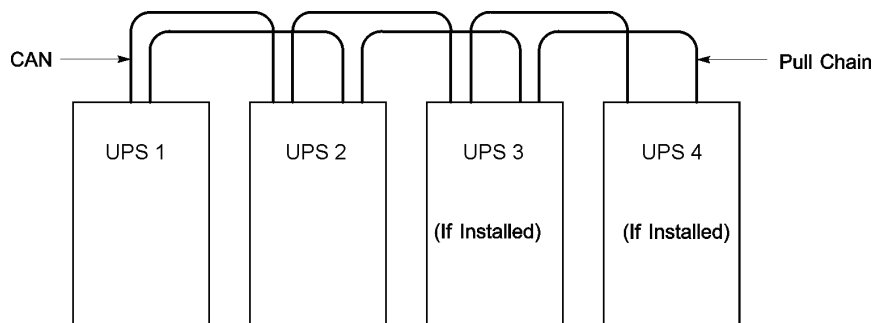

Figure 4-11: Simplified CAN and Pull-Chain Wiring for Parallel UPS System



NOTE

This drawing is for distributed bypass wiring purposes and is not a floor layout plan. UPPs can be placed in any physical order.



NOTE

External CAN connections between UPPs require 3-core shielded twisted pair wire (22AWG).

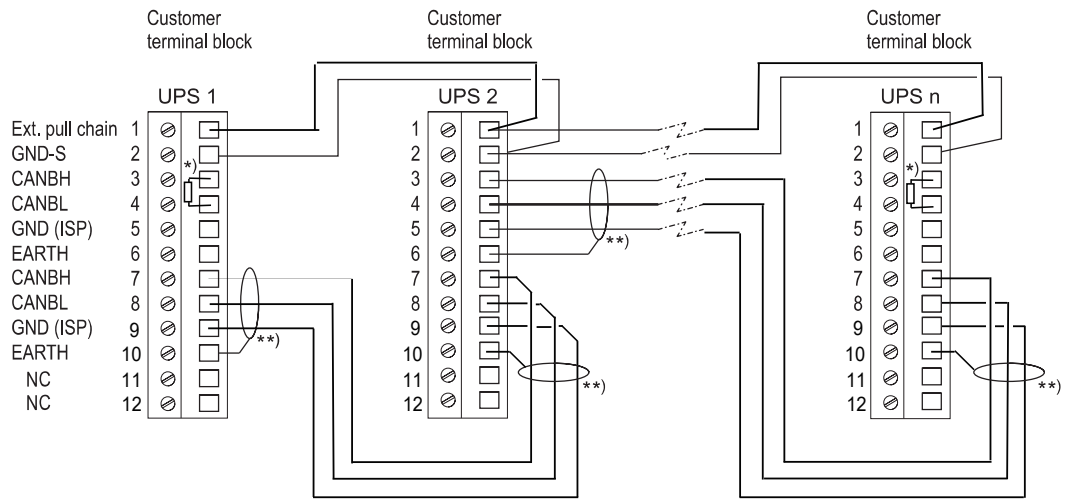

- *) First and last UPS shall be terminated with resistor
- ***) Shield connected on one end only

Figure 4-12: CAN and Pull-Chain Wiring for Parallel UPS

4.7.4. Installing Santak Sync Control

Refer to the operating instructions provided with the Santak Sync Control.

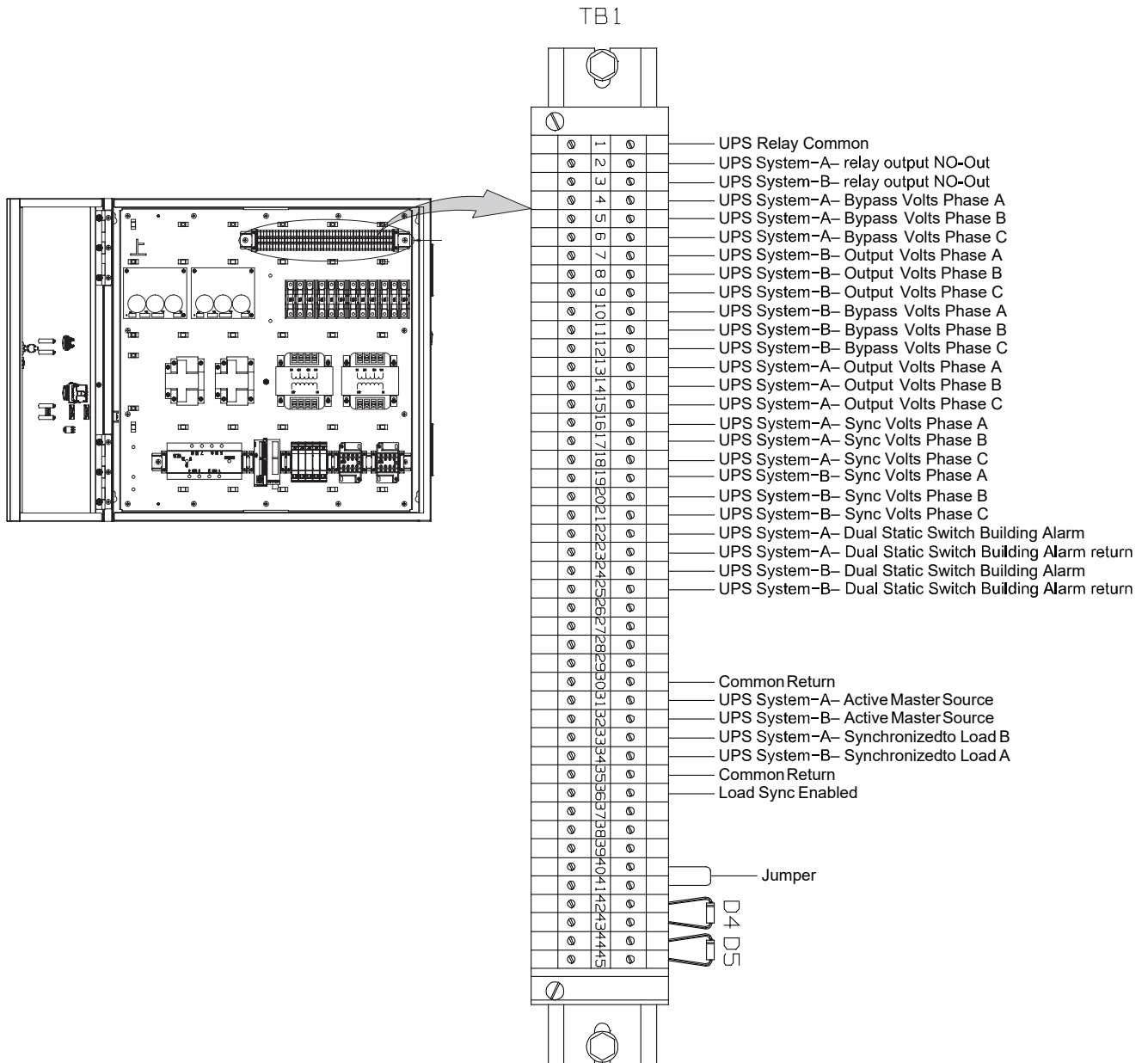

Figure 4-13: Sync Control TB1 Terminal Location



Chapter 5 COMMUNICATION INTERFACES

This section describes the communication features of the 3C3 HD UPS.

The UPS has the following communication interfaces:

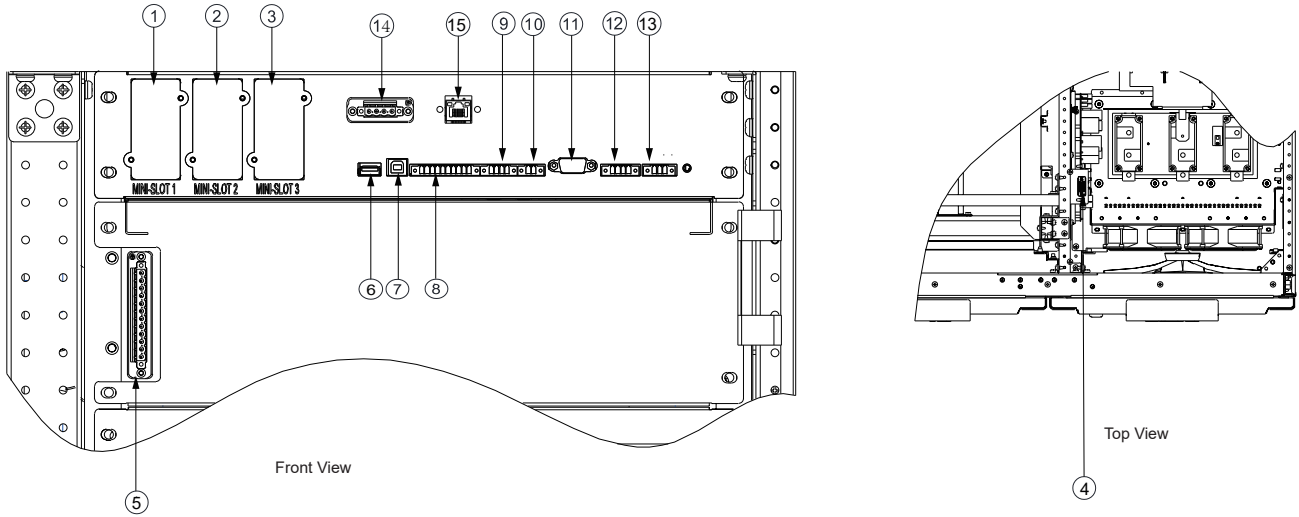

Figure 5-1: Communication Interfaces

- | | | | |
|--------------------------------|--------------------------------------|--|--|
| 1. Mini-slot 1 | 2. Mini-slot 2 | 3. Mini-slot 3 | 4. External Battery Breaker Trip & Auxiliary |
| 5. External Parallel Connector | 6. USB Host (connection to computer) | 7.USB Device (connection to accessories) | 8. Signal Inputs |
| 9. Customer CAN | 10.CAN Terminal | 11.RS-232 Port for Service | 12. Emergency Power Off (EPO) |
| 13. Output Relay | 14. RS-485 communication port | 15. RS-485 communication port | |

5.1. Mini-slots

The 3C3 HD UPS has three Mini-slot communication bays. The UPS is compatible with the following Mini-slot cards:

- **Gigabit Network Card**

The Santak Gigabit Network Card (Network-M2) is Santak's latest UPS network management card that delivers IT professionals with new and exciting capabilities and features. With better speed and cybersecurity, the Gigabit Network Card improves business continuity by providing warnings of pending issues to administrators and helping to perform orderly shutdown of servers and storage.



Figure 5-2: Gigabit Network Card

- **Environmental Monitoring Probe generation 2 (EMPG2)**

EMP Generation 2 can be used with Gigabit network card or industrial network card. EMP Generation 2 can support 4 devices in series, the highest communication distance up to 50 meter. EMPG2 can support easy installation through magnets on the back of its cover. It also has 2 additional input contact which can be self defined by users. By support of EMP, Web card, ETN IPM and ETN IPP can acquire real time temperature/humidity data. It can also be used for VAL battery temperature compensation.

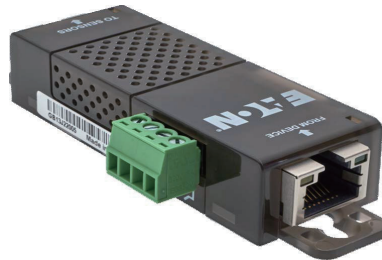

Figure 5-3: Environmental Monitoring Probe generation 2 (EMPG2)



- **Industrial Gateway Card**

The Santak Industrial Gateway Card (INDGW-M2) combines the features of an SNMP agent, HTTP/web server and a Modbus card to facilitate remote monitoring of your UPS system through any Building Management System. Enjoy the freedom to customize and schedule actions, like shutdown protocols and load shedding, and receive immediate notifications during power events, without having to be onsite.



Figure 5-4: Industrial Gateway Card

- **Relay Card-MS**

Two types of interfaces via a DB9 connector are available with this card. Dry contact mode provides a simple way to transmit UPS information to an alarm system, PLC, or computer system via dry relay contacts. By default the transmitted information is load powered, load on bypass, load on battery, load on utility, battery fault, and low battery. RS232 mode provides an RS232 interface for connection to a PC or to a UPS Control display unit. Jumpers are used to select the interface (contacts or RS232).

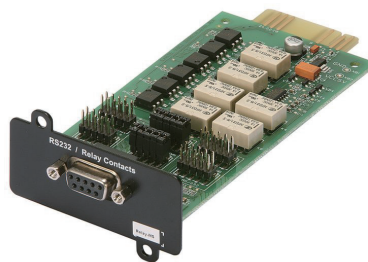

Figure 5-5: Relay Card-MS

• Intelligent Power Software

Intelligent Power Software are productivity tools for UPS power management. The Intelligent Power Protector (IPP) application provides automatic, graceful shutdown of computers and virtual machines or servers powered by an Santak UPS during a power outage that lasts longer than your available battery runtime. Intelligent Power Protector can be remotely supervised and managed by the Intelligent Power Manager (IPM) application. The IPM delivers a global view of power devices across the network from any PC with an Internet browser. The software enables single, Web-based interface for remote monitoring and management of Santak and other manufacturers' UPSs, environmental sensors and Power Distribution Units (ePDU) products, even in virtualized environments.

You can download it from the Santak web page.

5.2. Signal input Monitoring

This standard feature lets you connect the UPS to your signal inputs, such as on generator, charger on/off control, UPS on/off controls alarms. The customer interface terminals for external connections are located inside the UPS. You should use twisted-pair wires for each alarm input and common.

The signal inputs can be programmed to display the functional name.

5.3. General Purpose Relay Contact

One general purpose relay contact is provided as a standard feature on the UPS. An alarm contact is also provided. You can use a normally-closed or normally-open contact. If the state of the contact changes from the state you specify as normal, a signal is issued. You can connect this contact to equipment at your facility (such as a light or an alarm bell) to let you know when an alarm is active on the UPS. This feature is useful if the UPS is located in a remote area where the UPS horn may not be heard immediately.



NOTE

Contacts should not be operated in excess of 30 Vac (RMS) and 30 Vdc at 5 A maximum.



Chapter 6 UPS OPERATING INSTRUCTIONS

This section describes how to operate the UPS.



NOTE

- **Before starting the UPS, ensure all installation tasks are complete and a preliminary startup has been performed by authorized service personnel. The preliminary startup verifies all electrical interconnections to ensure the installation was successful and the system operates properly. Read these instructions and have a thorough understanding of UPS operation before attempting to operate any of the controls. The UPS is configured to operate with one of following nominal voltages: 380, 400, or 415 Vac. Before operating the UPS, confirm the UPS nominal voltage and frequency from display by selecting Settings -> Info. If the UPS need to be operated with another voltage or frequency, contact your closest Santak office or Santak authorized partner.**
 - **The UPS in not a measuring device. All displayed measurements are only approximate values.**
-

6.1. Ups Controls and Indicators

6.1.1. Control Panel

The control panel is used to set up and control the UPS, and to monitor UPS operation. For a description of the UPS control panel functions, see Section [6.2 Control Panel](#).

6.1.2. LPS

The LED Power Show (LPS) consists of two rows of LEDs located on the left and right sides of the UPS cabinet door. The LEDs are of red, green and yellow (RGY). The color of the LEDs is used to show the condition of the UPS. Only one color is shown at one time. The most urgent condition is always shown. The priority rank is Red, Yellow and Green.

The picture takes a 600kW cabinet as an example

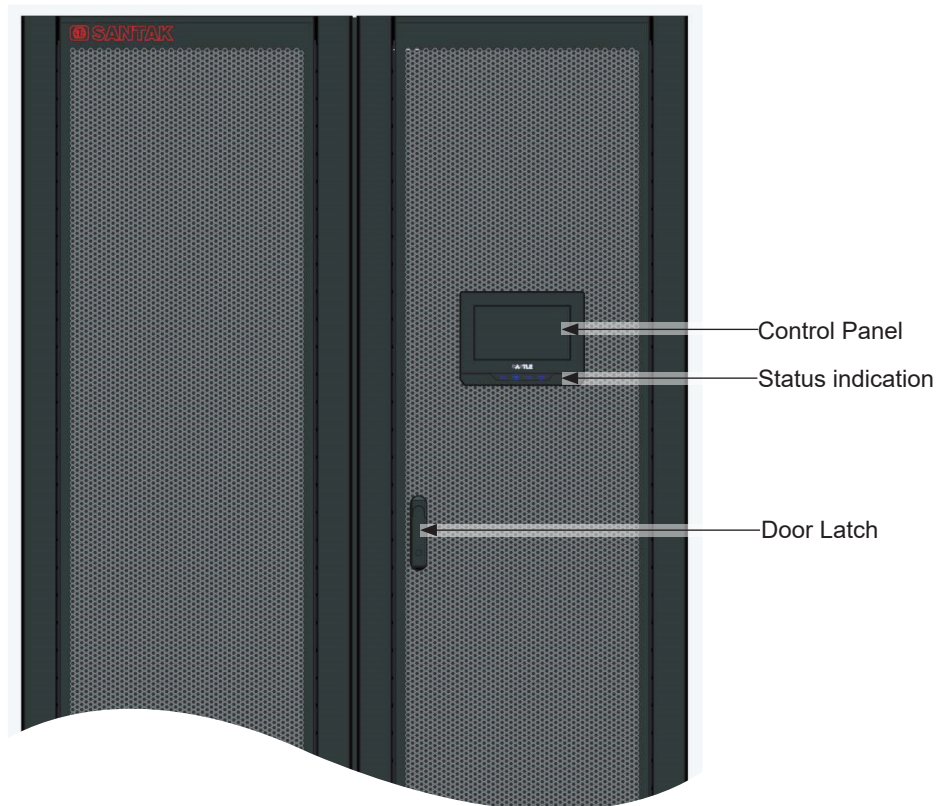

Figure 6-1: UPS Controls and Indicators

Table 6-1: Status Indicator

UPS Status	UPS Status Indicator (See Table 6-2)
Normal mode	Green lighting
Battery Mode	Yellow, Green
Bypass Mode	Yellow
ESS Mode	Green
ECT Mode	Yellow, Green
Alarm or Fault	Red



6.2. Control Panel

The following sections describe the UPS control panel and how to monitor and control UPS operation.

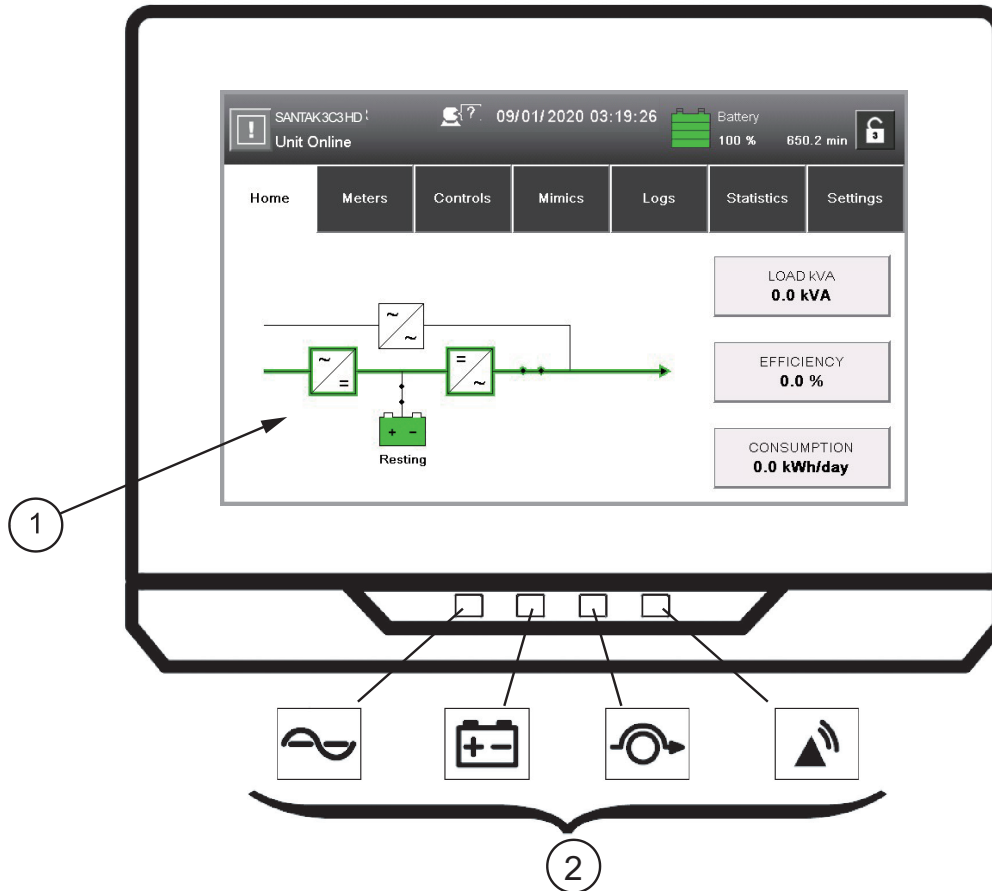

Figure 6-2: UPS Color Touch screen Control Panel (Typical)

The color touchscreen control panel consists of:

- A color liquid crystal touch screen display (1)
- A horizontal row of LED indicators (2)





Before system power up, the panel displays a system status screen similar to the one shown in the figure above.

When the unit powers up, the screen displays as shown in the figure above. When power is applied to the system, the display advances to the Sign In screen shown Parts of the Touch Screen.

6.2.1. Status Indicators

The four symbols below the display are status indicators. They are colored light emitting diode (LED) lamps, and they work in conjunction with the alarm horn to let you know the operating status of the UPS.

Table 6-2: Status Indicator

LED Indicator	Status	Description
 Green Symbol	On	The UPS is operating normally and supplying power to the critical load.
	Off	The UPS is turned off.
 Yellow Symbol —Battery Mode	On	The UPS is in Battery Mode. Because Battery Mode is a normal condition of the UPS, the Normal indicator also remains illuminated.
 Yellow Symbol —Bypass Mode	On	The UPS is in Bypass Mode and the power is supplied from bypass. The Bypass Mode indicator light is on while the Normal Mode indicator light is off.
 Red Symbol	On	Please pay attention immediately when UPS has an alarm. There is the current most important alarm on the screen. All warning signals will be with alarm sound, please press any button on HMI to stop it. "Alarm" light can be lit with other lights.

6.2.2. Signing In

The touch screen control panel provides an operator interface with the UPS system. [Figure 6-3](#) identifies the display areas discussed in the following sections.

Touching anywhere on the screen brings up the Sign In Request pop-up. Touch the X in the upper right corner of the pop-up, then touch the padlock symbol in the upper right corner to obtain the password request pop-up (see [Figure 6-4](#)).

If the level 1 password is enabled, you need to sign in.

1. Press the lock  button in the upper right corner of the screen.
2. Type your passcode and press **OK**.
3. You are signed in. Press **Continue** to return to the previous screen.

There are three attempts to input the password. If an incorrect password is given more than three times, you need to wait for 30 minutes before trying again. To modify the user settings, you need to enter level 2 password. For the default passwords, [Chapter 11 APPENDIX A: USER SETTINGS](#)

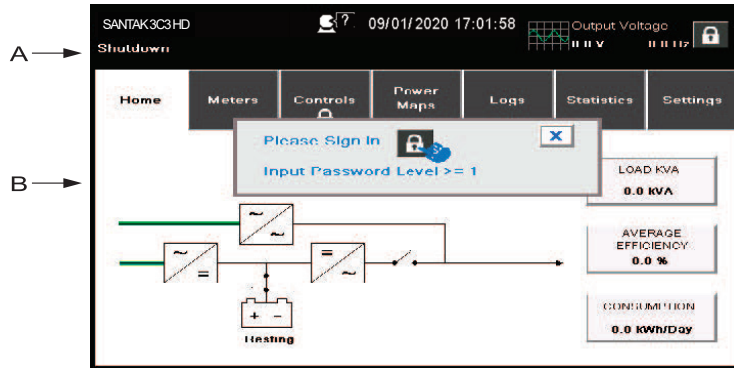

Figure 6-3: Parts of the Touch Screen

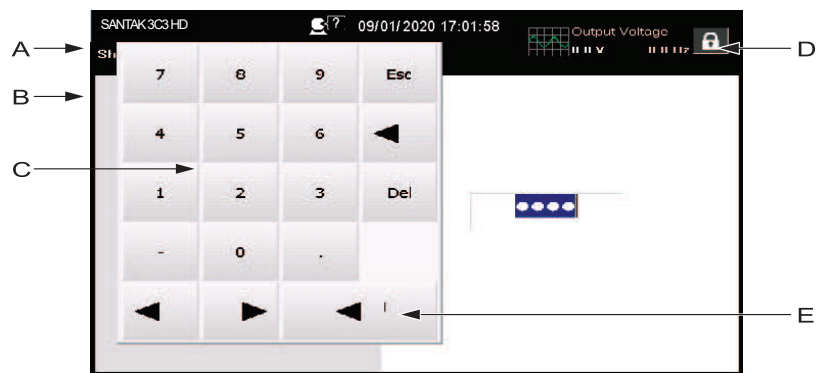

Figure 6-4: Sign In or Password Request Screen

A	<p>The UPS status area automatically displays the Santak model number, current time and date, active alarms, active notices, and load percent and battery run time for the UPS. If the Environmental Monitoring Probe is installed, the temperature and humidity sensed by the probe will also be displayed.</p> <p>The small head symbol between the system model and time allows the operator select a different language from an imbedded list.</p> <p>The top line of the display blinks while scrolling when the system needs attention. Some notices and alarms may be accompanied by an audible horn. To silence the horn, touch anywhere on the control panel once. For more information about alarms and notices, see Section 6.2.7 Logs.</p>
B	<p>The information area contains data about UPS status and operations.</p>
C	<p>After touching the padlock in the upper right corner, the numerical keypad appears to allow entry of the system access pass code for operation. See the following Table 6-3.</p>
D	<p>The padlock number indicates security level 0 - 3.</p>
E	<p>ENTER button.</p>

Table 6-3: Security Levels and Functions

Level	Name	Passcode	Description
0	USER	NONE	USER
1	CONTROL	1111	USER + CONTROL
2	CONFIGURATION	0101	USER + CONTROL + CONFIGURATION
3	SERVICE	Service Only	USER + CONTROL + CONFIGURATION + SERVICE

6.2.3. Home Screen(online)

Use the UPS menu bar to display information in the information area to help you monitor and control the operation of the UPS. The following table shows the basic menu structure.

Table 6-4: UPS Menu Structure

Main menu	Submenu	Description
Home	-	An overview of UPS operation, including information on load efficiency and consumption.
Meters	Meters Summary	Summary of UPS system meters.
	Input Meters	Detailed information on UPS or system input meters.
	Bypass Meters	Detailed information on UPS or system bypass meters.
	Output Meters	Detailed information on UPS or system output meters.
	Battery Meters	Detailed information on UPS or system battery meters.
Controls	System Controls	Go to bypass, Load Off / Start system.
	Ups Controls	Start charger, Run battery test, Shut down / Start UPS.
	Module Controls	Start charger, Run battery test /Shut down / Start.
	EAA Controls	ESS configuration, VMMS configuration , ABM configuration, clear logs/status/alarms.
Mimics	Ups Mimic	An overview of UPS operation, including information on load, efficiency and consumption. If there is a alarm, an error indicator is displayed next to the affected part. Active events log can be opened by tapping the error indicator.
	Ups Module Map	Module map shows the status of each UPM.
	System Overview	System overview shows the status of each UPS.
Logs	Active Events	All active events are displayed.
	System Log	log of all system events.
	Service Log	log of UPS operation.
	Change Log	Log of all changed settings and details.
Statistics		Displays UPS statistical data (uptime, downtime, maintenance, efficiency, etc).
Settings	User	Settings include date and time for the time stamp, display language, the unit name, meter subscripts, password, and view the firmware version numbers Used only by service personnel. See Chapter 11 APPENDIX A: USER SETTINGS for details.
	Configuration	
	Service	



Figure 6-5 shows Home Screen. The “Home” screen shows a real-time graph of UPS running status.

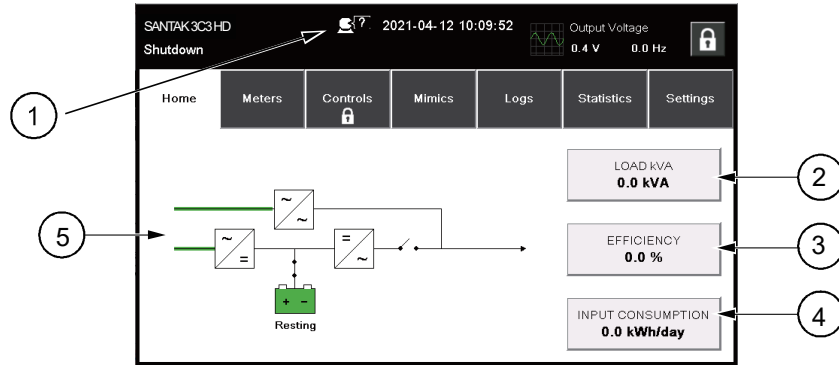

Figure 6-5: Home Screen

- ① Allows selection of alternate language
- ② See [Figure 6-6 Output kVA Screen from Home Screen](#)
- ③ See [Figure 6-7 Average Efficiency Screen from Home Screen](#)
- ④ See [Figure 6-8 Consumption Screen from Home Screen](#)
- ⑤ Schematic diagram showing the flow of electric energy



NOTE

- On all screens, Black lines indicate NO power flow, Green lines indicate ACTIVE power flow, Yellow lines indicates an out-of-tolerance condition.
- Screens shown are representative examples of system operation. The screen data will vary based on system activity at the time of observation.

Touching the LOAD kVA button displays the Output kVA screen shown in [Figure 6-6](#).

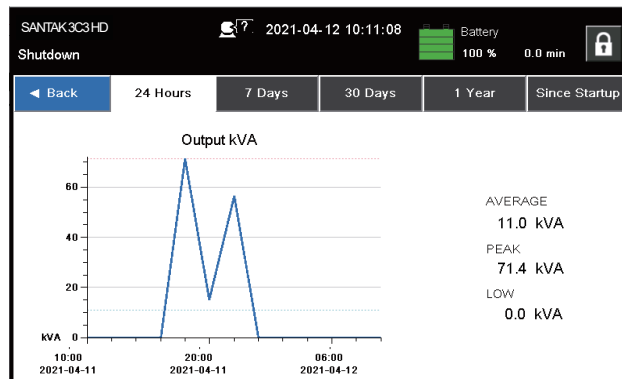

Figure 6-6: Output kVA Screen from Home Screen

Touching the AVERAGE EFFICIENCY button displays the system efficiency screen shown in [Figure 6-7](#).

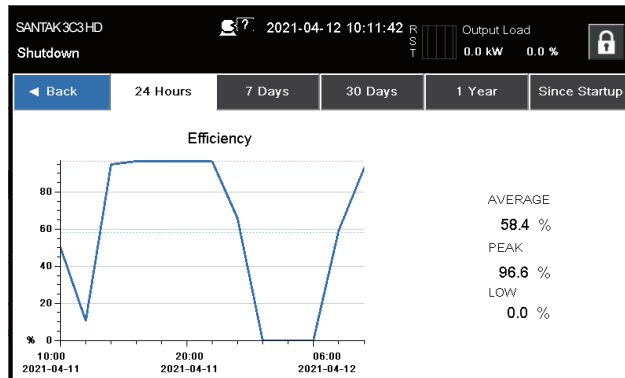

Figure 6-7: Average Efficiency Screen from Home Screen

Touching the CONSUMPTION button displays the screen shown in [Figure 6-8](#).

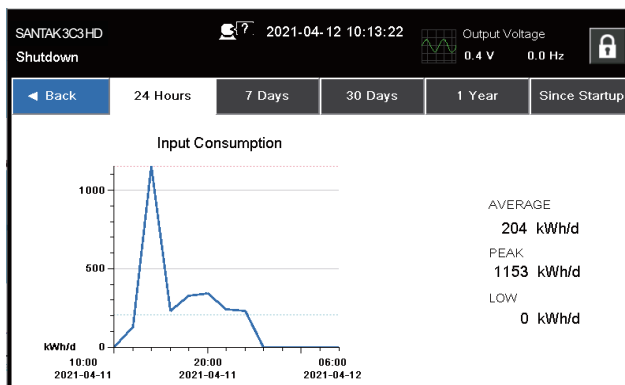

Figure 6-8: Consumption Screen from Home Screen



6.2.4. Meters

Meters Summary Screen

[Figure 6-9](#) shows the Meters Summary screen. This screen allows selection of the various metering readout functions of Input, Output and overall System status.

The three left items in the OVERVIEW section of the screen are not active buttons but are status detail panels. They show individual conditions of the UPS at that time.

The two items at the far right of the OVERVIEW section are active buttons. They can be selected to show a profile of efficiency or consumption over various time periods of 24 hours, 7 days, 30 days, or 1 year. This is true of all the meters screens listed in the top section.

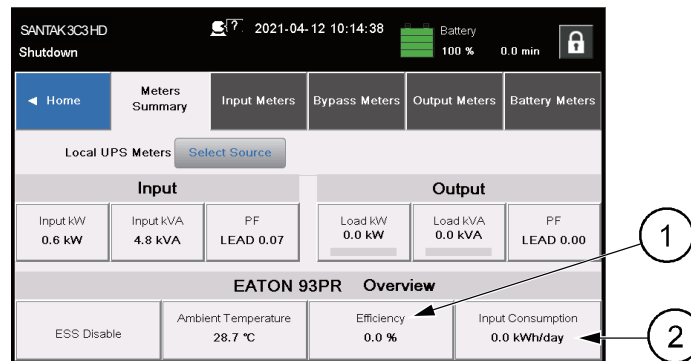

Figure 6-9: Meters Summary Screen

- ① See [Figure 6-7 Average Efficiency Screen](#) ② See [Figure 6-8 Consumption Screen](#) from Home Screen

Input Meters Screen

[Figure 6-10](#) shows the Input Meters screen. This screen displays the individual phase and total power values of the system.

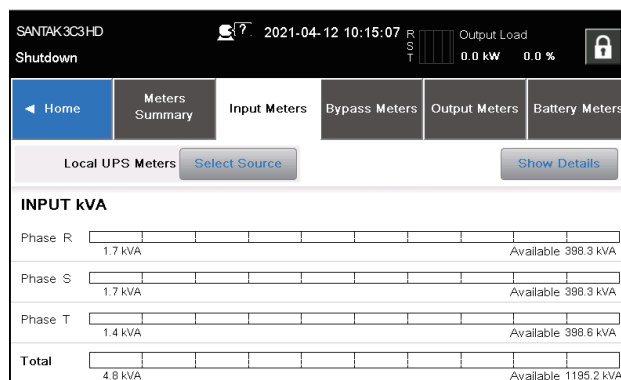

Figure 6-10: Input Meters Screen

Bypass Meters Screen

The Bypass Meters Screen shown in *Figure 6-11* displays values pertaining to the Bypass conditions.

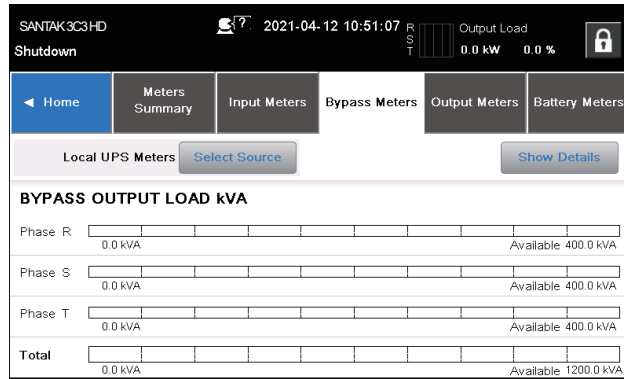

Figure 6-11: Bypass Meters Screen

Output Meters Screen

The Output Meters Screen shown in *Figure 6-12* displays values pertaining to the system output.

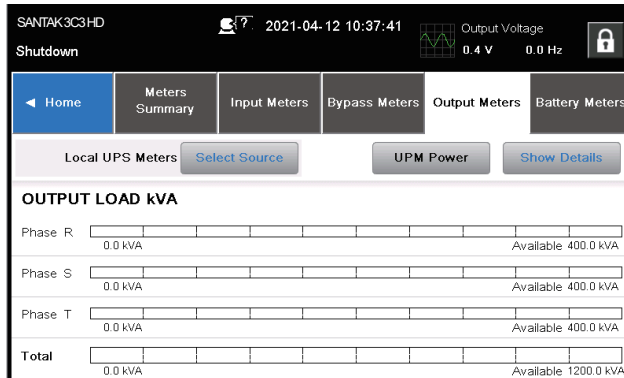

Figure 6-12: Output Meters Screen



Figure 6-13 shows the Input Meters detail screen. This screen displays the individual values of the system in additional detail. The Bypass, Output, and Battery meters screens display similar values relevant to their monitoring of the system.

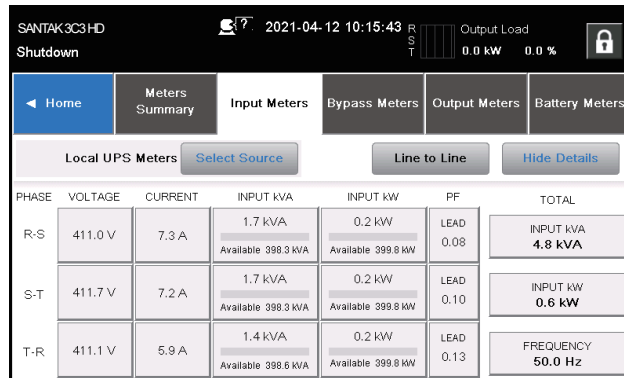

Figure 6-13: Input Meters Detail Screen

Click the "line voltage" button to select the line to line or line to neutral monitoring values. See Figure 6-14.

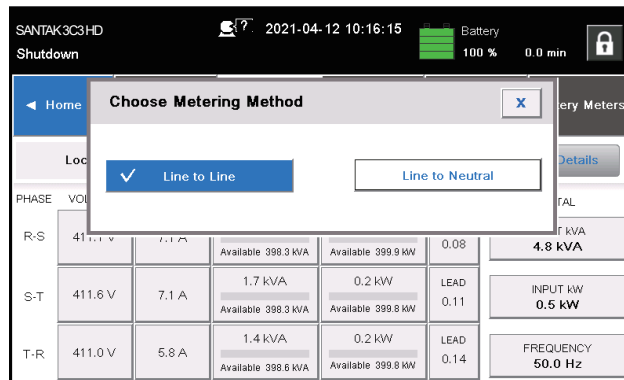

Figure 6-14: Online Mode Metering Method Option Screen

The Select Source screen shown in Figure 6-15 allows the operator to choose the individual source for system readings.

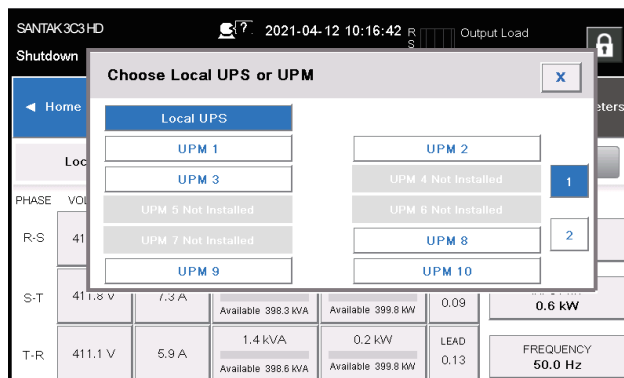

Figure 6-15: Select Source Screen

Battery Meters Screens

Figure 6-16 shows the Battery Meters basic screen.

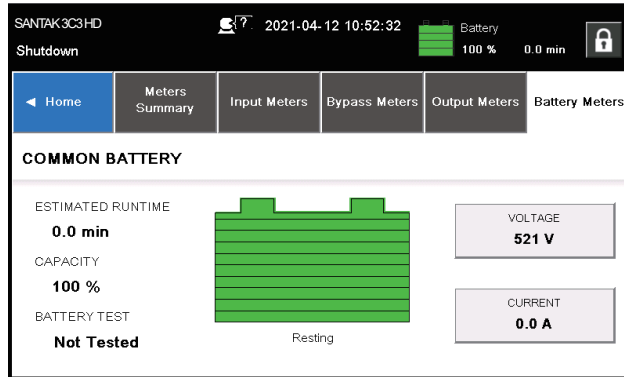

Figure 6-16: Battery Meters Screens

Click the "Voltage" button, Figure 6-17 show a profile of battery voltage over various time periods of 24 hours, 7 days, 30 days, or 1 year.

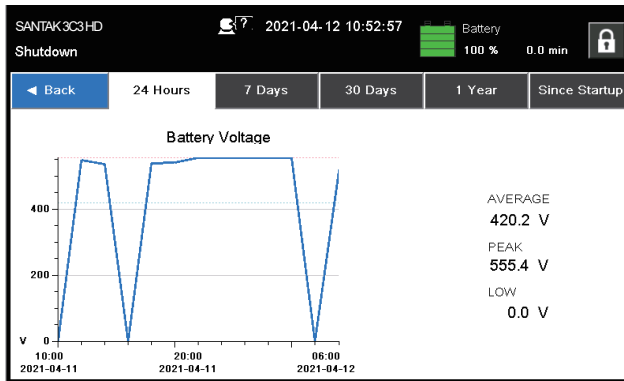

Figure 6-17: Battery Voltage Screens

Click the "Current" button, Figure 6-18 show a profile of battery Current over various time periods of 24 hours, 7 days, 30 days, or 1 year.

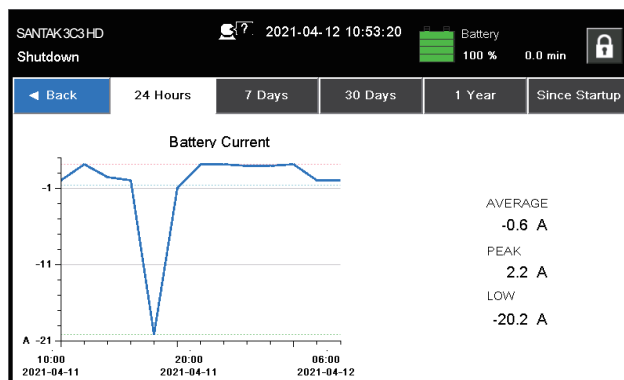

Figure 6-18: Battery Current Screens



Lithium Battery Meters Screens

The battery-related values of the Lithium Battery Measurements screen are shown below

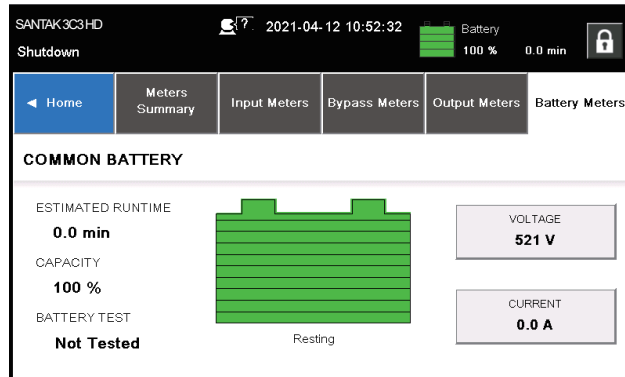

Figure 6-19: Lithium battery measurement screen

First configure the lithium battery enable function, then enter the Meter page, double-click the "Battery Meters" button to enter the lithium battery display page.

The lithium battery page mainly displays the following parameters: SOC, SOH, cell voltage, cell temperature. When the UPS lithium battery is abnormal, the HMI interface will display relevant alarms.

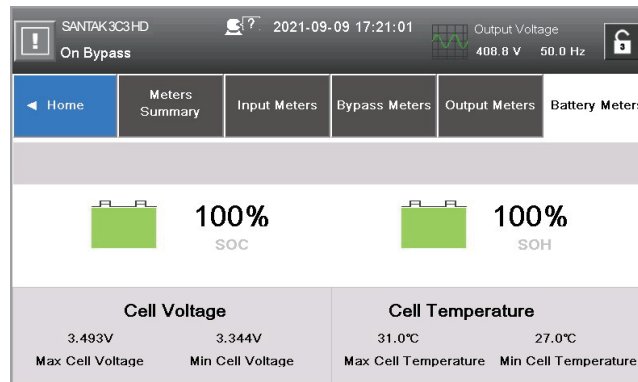

Figure 6-20: Lithium battery interface

6.2.5. Controls

System Controls Screen

Press the "Control" button on the main menu bar to display the "System Control" screen. From this screen, you can control online operation, transfer to bypass, shutdown and load off commands. In addition, this screen can display the current status of the UPS, indicating whether the UPS is in "online mode" or "bypass mode". [Figure 6-21](#) shows the System Status screen.

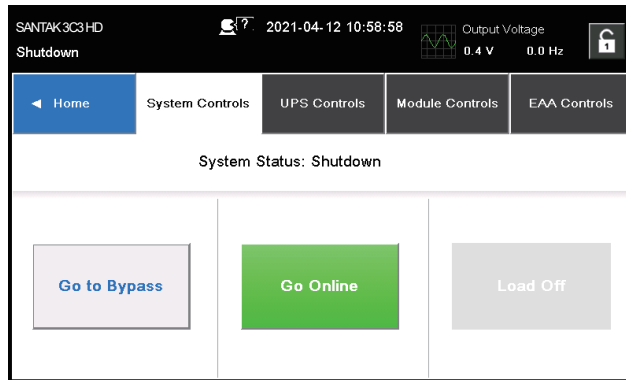

Figure 6-21: System Controls Screen

UPS Controls Screen

This screen can control the charger, battery test and UPS status.

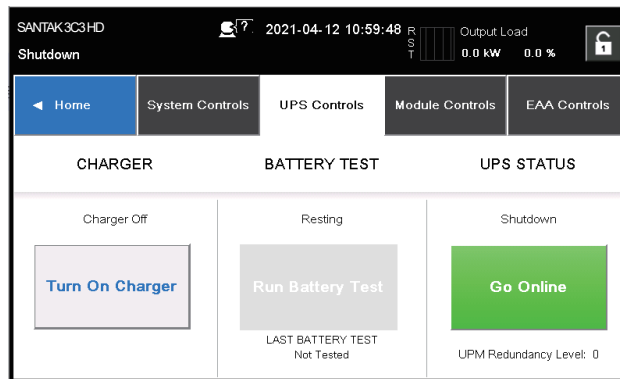

Figure 6-22: UPS Controls Screen



Module Controls Screen

Figure 6-23 shows the Module Controls screen. This screen can control each module in the system and display the value and status of each UPM.

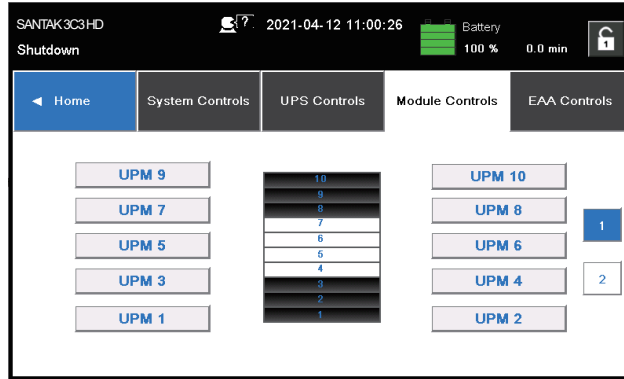

Figure 6-23: Module Controls Screen

Figure 6-24 shows the Module Control screen. By selecting any of the modules shown on the previous screen (Figure 7-33), the user can observe full details of an individual module. It also allows the user to move through various modules and modes while within this screen.

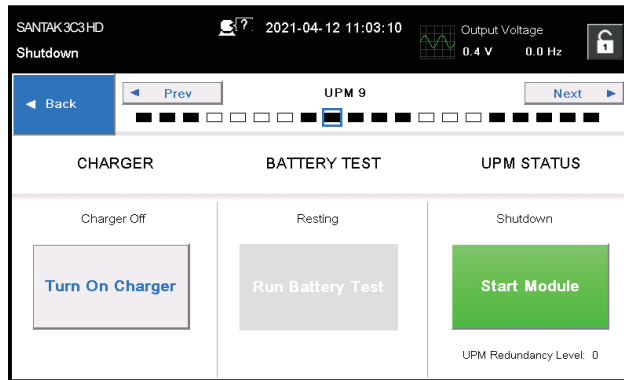

Figure 6-24: Module Control Detail Screen

Select the "Turn On Charger" button, there will be a pop-up screen to confirm the request.

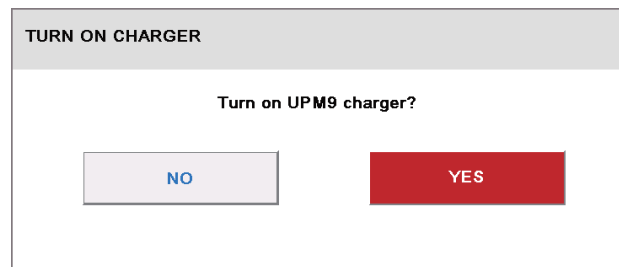

Figure 6-25: Turn On Charger confirmscreen

Energy Advantage Architecture (EAA) Screen

This screen shown in [Figure 6-26](#) allows the operator to activate the various energy saving and power efficiency modes of the system.

The various Energy Advantage Architecture operations are described in the UPS Installation and Operation manual for your system.

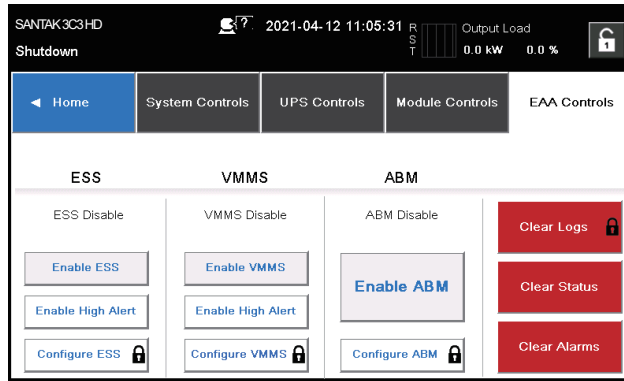

Figure 6-26: Energy Advantage Architecture (EAA) Screen

Select the "Enable ESS" button, there will be a pop-up screen to confirm the request. For details, see [Section 2.2.1.2](#).

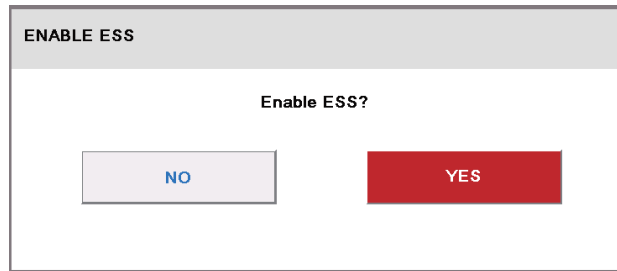

Figure 6-27: Enable ESS Confirmscreen

Select the "Enable VMMS" button, there will be a pop-up screen to confirm the request. For details, see [Section 2.3.4](#).

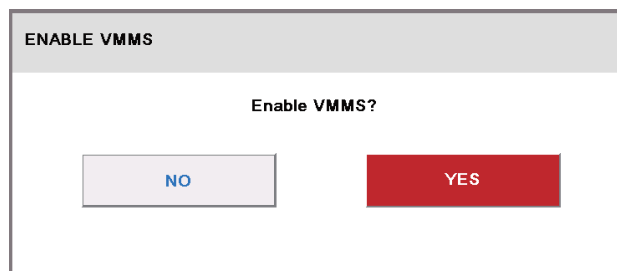

Figure 6-28: Enable VMMS Confirmscreen



Select the "Enable ABM" button, there will be a pop-up screen to confirm the request. For details, see Section [2.3.1](#).

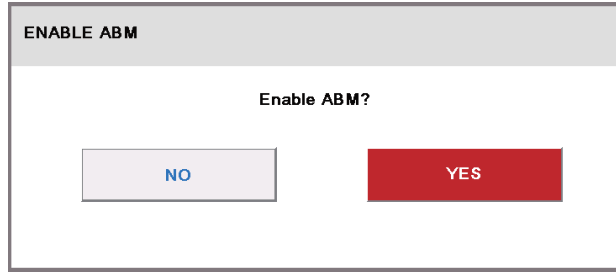

Figure 6-29: Enable ABM Confirmscreen

Select the "Clear Alarms" button, there will be a pop-up screen to confirm the request.

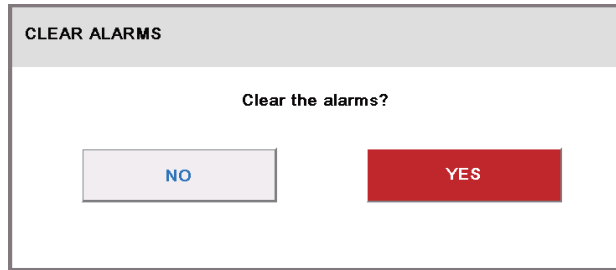

Figure 6-30: Clear Alarms Confirmscreen

6.2.6. Mimics

Press the "UPM Mimic" on the main menu to display the mimic screen, which is used to observe the power flow, as shown in the figure below:

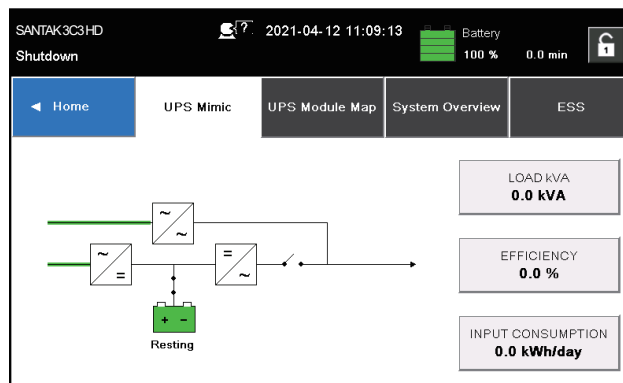

Figure 6-31: UPS Mimic Screen

The screen shown *Figure 6-32* allows the operator to control the individual UPMs.

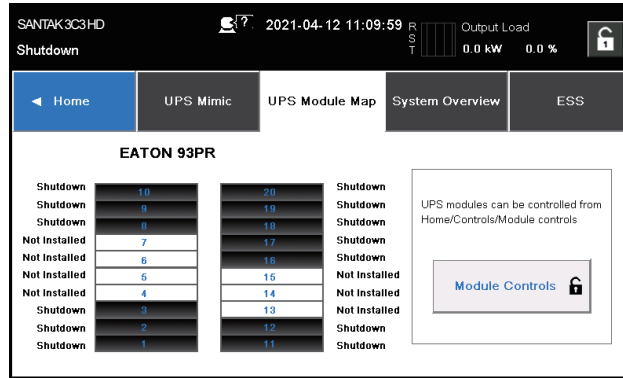

Figure 6-32: UPS Module Map Screen

The screen shown *Figure 6-33* displays values for all UPS and UPM parameters.

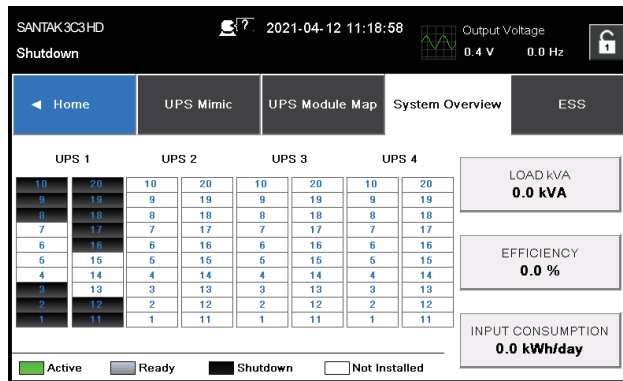

Figure 6-33: System Overview Screen

The screen shown *Figure 6-34* allows the operator to visually obtain ESS mode efficiency values.

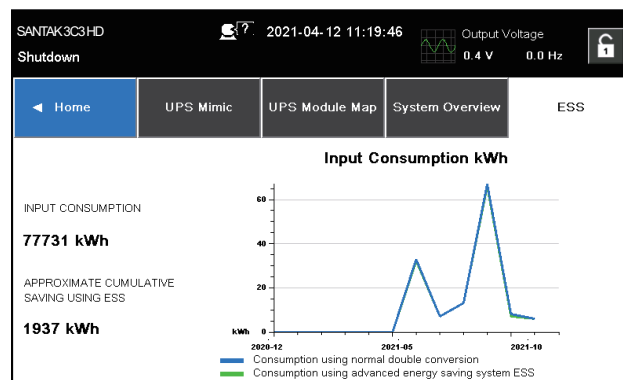

Figure 6-34: ESS Screen



6.2.7. Logs

System Events Main Screen

When the UPS system is running in Online mode, it will continuously monitor whether the UPS has alarms. In Battery or Bypass modes, the UPS may issue alarms to display exactly what event caused the change from Online mode. System events on the UPS can be indicated by horns, lights, messages, or all three. See [Figure 6-35](#).

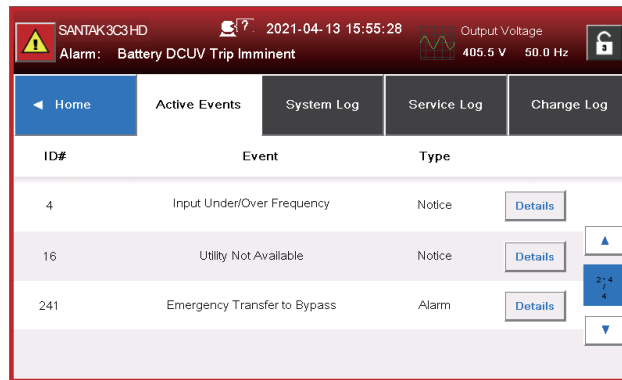

Figure 6-35: System Events Screen

System Log

In Battery or Bypass Modes, the UPS may issue alarms to let you know exactly what event caused the change from Double Conversion Mode. System events on the UPS can be indicated by horns, lights, messages, or all three.

Select **Logs** from the main menu screen to look at any currently active events.

- **System Event Horn** - The system event horn beeps to alert an operator that an event needing attention is taking place.
- **System Event Indicators** - The status indicators on the UPS control panel and the event horn let you know when the UPS system is operating in any mode other than Double Conversion Mode. Only the Normal indicator is visible during normal UPS system operation. The other indicators illuminate to indicate alarms or events (see [Table 6-1](#)). When an alarm occurs, first check these indicators to see what type of event has taken place.
- **System Event Messages** - When a system event occurs, a message appears in the status bar of the display. This message is also written to the Active Events log. Some notices and alarms may be accompanied by an audible horn. To silence the horn, press any button once.

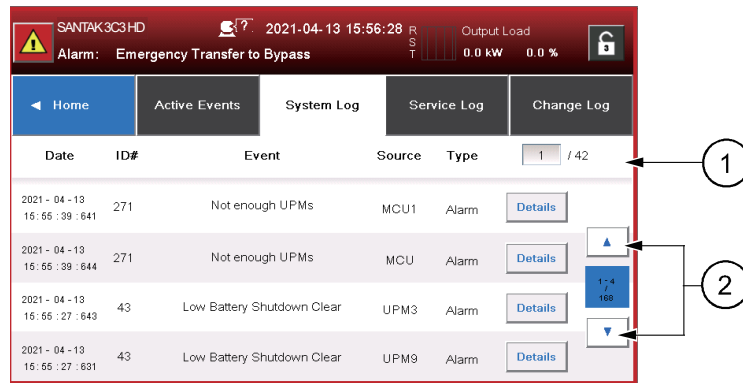

Figure 6-36: System Log Screen

- ① Allows the operator to enter any number up to the number shown to the right of the box. Each window shows four events.
- ② The operator can also use the UP/DOWN arrows above and below showing the number of events in the log.

Selecting an event opens the Event Detail screen shown in [Figure 6-37](#). This screen details the specifics of the event for the user to see.

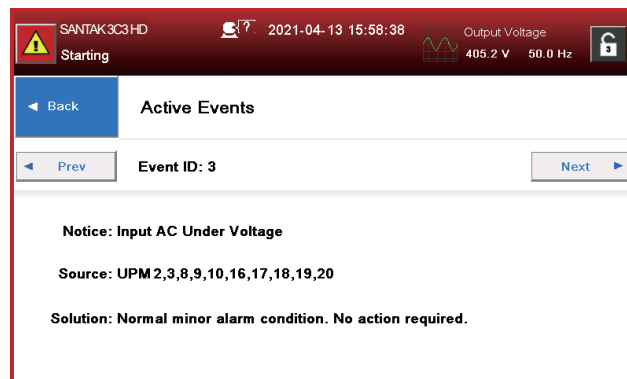

Figure 6-37: Active Event Detail Screen



Service Log Screen

The "Service Log" screen displays service alarms, service notifications and service status, as shown in the figure below:

The screenshot shows the Service Log screen for a Santak 3C3HD UPS. The top status bar displays 'SANTAK3C3HD Shutdown', the time '2021-04-12 11:21:57', and 'Output Voltage 0.4 V 0.0 Hz'. The navigation menu includes Home, Active Events, System Log, Service Log (selected), and Change Log. The main table lists events with columns for Date, ID#, Event, Source, and Type. There are also 'Details' buttons and a page indicator '1 / 1024'.

Date	ID#	Event	Source	Type	
2021 - 04 - 12 10:07:05:727	202	Bypass Not Available Clear	MCU	Notice	Details
2021 - 04 - 12 10:07:05:638	202	Bypass Not Available Clear	MCU1	Notice	Details
2021 - 04 - 12 10:06:55:938	203	Backfeed Switchgear Closed	MCU	Status	Details
2021 - 04 - 12 10:06:55:930	203	Backfeed Switchgear Closed	MCU1	Status	Details

Figure 6-38: Service Log Screen

Change Log

The "Change Log" screen displays the system configuration change information, as shown in the figure below:

The screenshot shows the Change Log screen for a Santak 3C3HD UPS. The top status bar displays 'SANTAK3C3HD Shutdown', the time '2021-04-12 11:23:06', and 'Output Load 0.0 kW 0.0 %'. The navigation menu includes Home, Active Events, System Log, Service Log, and Change Log (selected). The main table lists events with columns for Date, Event, and CPU ID. There are also 'Details' buttons and a page indicator '1 / 25'.

Date	Event	CPU ID	
2021 - 04 - 09 15:24:57:791	Safety Key Entered Incorrectly	CSB	Details
2021 - 04 - 09 15:24:57:080	Safety Key Entered Incorrectly	CSB	Details
2021 - 04 - 09 15:24:52:836	Safety Key Entered Incorrectly	CSB1	Details
2021 - 04 - 09 15:24:51:378	Safety Key Entered Incorrectly	CSB1	Details

Figure 6-39: Change Log Screen

6.2.8. Statistics

Statistics Basic Screen

The screen shown in [Figure 6-40](#) allows the operator to query the system for various operational statistics.

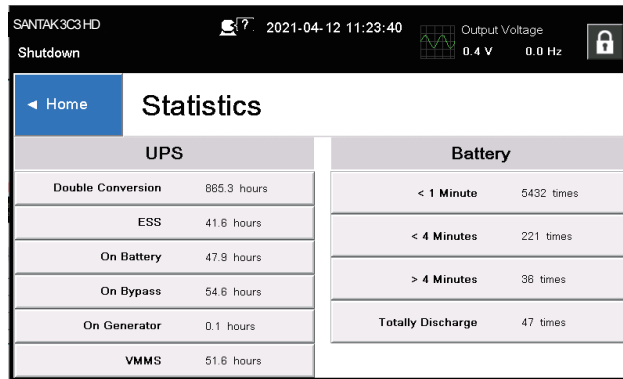

Figure 6-40: Statistics Data Detail Screen

6.2.9. Settings

User Screen

The screen shown in [Figure 6-41](#) gives the operator access to basic system information such as serial number, installed firmware version, etc. Touching the CLEAN SCREEN button disables the screen for 30 seconds to allow the user to safely clean the screen without affecting operation.

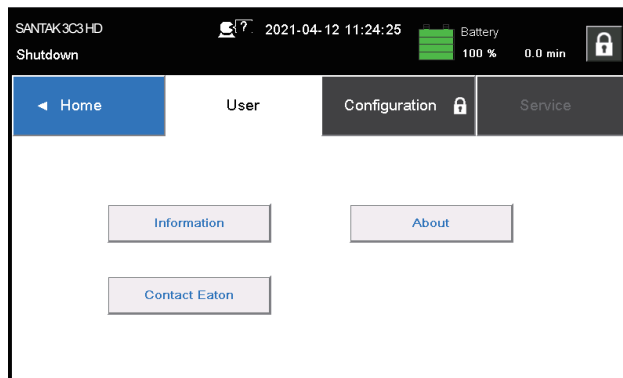

Figure 6-41: User Screen Screen



Configuration Options Screen

The screen shown in [Figure 6-42](#) allows the operator to affect changes to various system values.

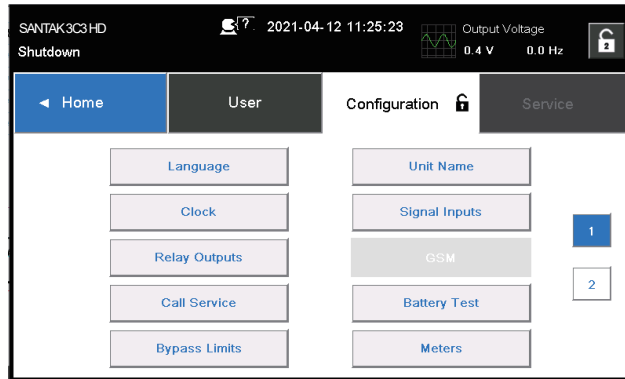

Figure 6-42: Configuration Options Screen

Service Screen

The "Service" screen is only used for Santak service engineers, as shown in the figure below:

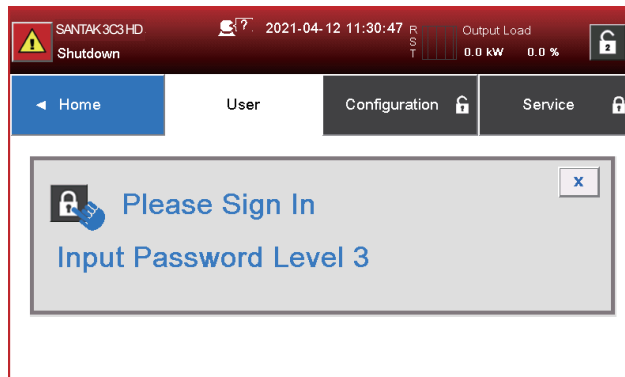

Figure 6-43: Prompt for level 3 Password Screen

6.3. System Control Instructions

6.3.1. Starting the UPS System in Double Conversion Mode

The UPS system can consist of a single UPS or several parallel UPSs.

To start the UPS system:

1. Unfasten the front door latch and swing the door open.
2. (If the UPS contains) Verify that rectifier input switch, output switch, bypass switch are closed the UPS system, and close the front door.
3. Close the UPS input feeder circuit breaker.
4. Close the UPS bypass input feeder circuit breaker.
5. Observe the UPS control panel display becoming active, indicating logic power. Repeat steps 1-5 for each individual UPS in the system.
6. Press the **Controls** button in the main menu. The System Controls screen appears.
7. On the System Controls screen, the system status should indicate SHUTDOWN.
8. Press the Go online button on the System Controls screen. If Auto Bypass is enabled, the critical load is immediately supplied by the bypass source, in Bypass Mode, until the inverter turns on and the UPS transfers to Double Conversion Mode. The status indicator on the UPS control panel indicates the UPS is in Bypass Mode. If auto bypass is not enabled, the UPS output remains off until the UPS system transfers to Double Conversion Mode.
9. Observe the following messages appear sequentially on the System Controls screen:

STARTING
ONLINE

The rectifier and inverter turn on. The DC voltage continues to ramp up to full voltage. Once the DC link reaches full voltage, and the battery breaker is closed, the UPS output relay K3 closes and the static switch turns off. Power is now supplied to the Critical load in Double Conversion Mode. It takes approximately 20 seconds for the UPS system to achieve Double Conversion Mode.

10. The UPS system is now operating in Double Conversion Mode and the NORMAL status indicator is illuminated in all UPSs in the system.

6.3.2. Starting the UPS System in Bypass Mode

If the inverter output of the UPS is not available and the critical load needs to be energized, perform the following procedure:



CAUTION



In Bypass Mode, the critical load is not protected from commercial power interruptions and abnormalities.

1. Unfasten the front door latch and swing the door open.
2. (If the UPS contains) Verify that rectifier input switch, output switch, bypass switch are closed the UPS system, and close the front door.
3. Close the UPS input feeder circuit breaker.
4. Close the UPS bypass input feeder circuit breaker.
5. Observe the UPS control panel becoming active, indicating logic power. Repeat steps 1-5 for each single UPS in the system.
6. Press the **Controls** button in the main menu. The System Controls screen appears.
7. On the System Controls screen, the system status should indicate SHUTDOWN.
8. Press the **Go to bypass** button in the System Controls screen.
9. The critical load is immediately supplied by the bypass source, in Bypass Mode.
10. The UPS system is now operating in Bypass Mode and the BYPASS status indicator is illuminated.

6.3.3. Transfer from Double Conversion Mode to Bypass Mode

To transfer the critical load to Bypass Mode, perform the following procedure:



NOTE

In Bypass Mode, the critical load is not protected from commercial power interruptions and abnormalities.

1. Press the **Controls** button in the main menu. The System controls screen appears.
2. Press the **Go to bypass** button in the System Controls screen. The UPS system transfers to Bypass Mode and the critical load is immediately supplied by the bypass source. If the bypass source is not available, the power process or remains on and an alarm sounds.
3. The UPS system is now operating in Bypass Mode and the BYPASS status indicator is illuminated. The UPM status indicates READY. The system status indicates ON BYPASS.



DANGER

Power is present inside the UPS cabinets.

6.3.4. Transfer from Bypass to Double Conversion Mode

To transfer the critical load to Double Conversion Mode, perform the following procedure:

1. Press the **Controls** button in the main menu. The System controls screen appears.
2. Press the **Go online** button on the System controls screen. The UPS system transfers to double conversion mode. If enough UPM capacity is not available, the system remains

on bypass and an alarm sounds.

3. The UPS is now operating in Double Conversion Mode, and the NORMAL status indicator is illuminated. The system status indicates **UNIT ONLINE**.

6.3.5. Transfer from Double Conversion Mode to Energy Saver System Mode

Note that the Energy Saver System mode commands are displayed only if enabled at the factory or by an Santak Customer Service Engineer.

To transfer the critical load to Energy Saver System mode:

1. Switch to **Setting service** screen.
2. Select **EAA Controls**.
3. Select **Enable ESS**.

The entire UPS system transfers to Energy Saver System mode and the critical load is supplied by the bypass source. If the bypass source is not available or conditions are not correct for ECO mode, the power module remains on and an alarm sounds. The NORMAL status indicator is illuminated. The UPS status indicates UNIT ONLINE, ECO. The UPM status indicates READY.

6.3.6. Transfer from Energy Saver System Mode to Double Conversion Mode

Note that the Energy Saver System mode commands are displayed only if enabled at the factory or by an Santak Customer Service Engineer.

To transfer the critical load to Double Conversion Mode:

1. Switch to **Setting service** screen.
2. Select **EAA Controls**.
3. Select **Disable ESS**.

The UPS system transfers to Battery Mode and then to Double Conversion Mode. If the power module is not available, the system remains on bypass and an alarm sounds. The NORMAL status indicator is illuminated. The UPS status indicates UNIT ONLINE. The UPM status indicates ACTIVE.

6.3.7. UPS System and Critical Load Shutdown

To perform maintenance or service on the critical load, shut down power to the load by performing the following procedure:

1. Turn off all equipment that is being powered by the UPS system.
2. Perform the **LOAD OFF** procedure (see Section [6.3.8 De-energizing the Critical Load](#)). The input, output, and bypass backfeed contactors open, the battery breaker or disconnect is tripped, and the power module is turned off.



DANGER

Power is present inside the UPS cabinet until the upstream input feeder circuit breaker is opened.

3. Unfasten the front door latch and swing the door open.
4. (If the UPS contains) Close the UPS output switch, bypass switch, and close the front door.
5. Repeat steps 3-5 for all UPSs in the system.

6.3.8. De-energizing the Critical Load

A UPS system Load Off is initiated by the **Load Off** button from **Controls > System Controls** screen. This button can be pressed to control the UPS output. The **Load Off** button de-energizes the critical load and

Powers down the UPS system.

The UPS system (including Bypass) remains off until restarted.

1. Press **Load Off**.

The shut down screen appears, providing a choice to proceed or abort the shutdown.



NOTE

All power to the critical load is lost when Load Off is selected in the following step. You should use this feature only when you want to de-energize the critical load.

2. To shut down the UPS, press **Load Off**. To abort the shutdown, press ABORT. When **Load Off** is selected, the input, output, and bypass backfeed contactors open, the battery breaker or disconnect is tripped, and all the UPSs in the system are turned off.
-



DANGER

Power is present inside the UPS cabinet until the upstream input feeder circuit breaker is opened.

3. To restart the UPS system, follow the procedure in Section [6.3.1 Starting the UPS System in Double Conversion Mode](#) or Section [6.3.2 Starting the UPS System in Bypass Mode](#).

6.4. UPS Control Instructions

6.4.1. Starting a Single UPS

Ensure that load level does not exceed single UPS capacity.

To start the UPS

1. Unfasten the front door latch and swing the door open.
2. (If the UPS contains) Verify that rectifier input switch, output switch, bypass switch are closed the UPS system, and close the front door.
3. Close the UPS input feeder circuit breaker.
4. Close the UPS bypass input feeder circuit breaker.
5. Observe the UPS control panel display becoming active, indicating logic power.
6. Press the **Controls** button in the main menu. Press the **UPS controls** button.
7. On the UPS Controls screen, the system status should indicate SHUTDOWN.
8. Press the **Go online** button on the System Controls screen. If Auto Bypass is enabled, the critical load is immediately supplied by the bypass source, in Bypass Mode, until the inverter turns on and the UPS transfers to Double Conversion Mode. The status indicator on the UPS control panel indicates the UPS is in Bypass Mode. If auto bypass is not enabled, the UPS output remains off until the UPS system transfers to Double Conversion Mode.
9. Press the **Go online** button on the UPS control screen.
10. Observe the following messages appear sequentially on the UPS status line:

STARTING
ONLINE

The rectifier and inverter turn on. The DC voltage continues to ramp up to full voltage. Once the DC link reaches full voltage, and the battery breaker is closed, the UPS output relay K3 closes. Power is now supplied to the Critical load in Double Conversion Mode. It takes approximately 20 seconds for the UPS system to achieve Double Conversion Mode.

11. The UPS system is now operating in Double Conversion Mode and the NORMAL status indicator is illuminated.

6.4.2. UPS Shutdown

A single UPS in the system can be shut down only if it is redundant. In practice that means a UPS is not allowed to be shut down if doing so would lead to an overload condition in the remaining UPSs in the system.

To shut down a single UPS:

1. Press the **Controls** button in the main menu. The System controls screen is displayed.
2. On the **System controls** screen, press UPS controls.
3. On the **UPS control** screen, select Shut down UPS.



6.4.3. Enabling and Disabling the Battery Charger

To turn the battery charger on or off, perform the following procedure:

1. Press the **Controls** button in the main menu. The System controls screen appears.
2. On the **System controls** screen, press UPS controls.
3. Press the **Start charger / Stop charger** button.

6.5. Using the Remote Emergency Power-off switch

A UPS emergency power-off is initiated by the EPO pushbutton switch. In an emergency, you can use this switch to control the UPS output. The EPO switch de-energizes the critical load and powers down the UPS immediately, without asking for verification. The UPS, including Bypass, remains off until restarted.



CAUTION

All power to the critical load is lost when the EPO switch is activated in the following step. You should use this feature only when you want to de-energize the critical load.



NOTE

The following instructions are for the Santak Corporation-supplied EPO switch. If a customersuppliedEPO switch is used, it may not activate in the same manner; refer to the operating instructions provided with the switch.

To use the EPO switch:

1. Press the EPO pushbutton switch.

The input, output, and bypass backfeed relays open, the battery breaker or disconnect is tripped, and the power module is turned off immediately, without asking for verification.

2. To restart the UPS after using the EPO pushbutton, reset the EPO switch and then follow the procedure in [Section 6.3.1 Starting the UPS System in Double Conversion Mode](#) or [Section 6.3.2 Starting the UPS System in Bypass Mode](#).
-



DANGER

Do not attempt to restart the system after Load Off until the cause of the shutdown has been identified and cleared.



6.6. Transfer the UPS from Double Conversion Mode to Maintenance Bypass Mode

The operation of the internal MBS is allowed for a trained person only who is familiar with the UPS behavior and functions. The full UPS wiring diagram with a MBS switch is presented in the installation instructions.



NOTE

The integral MBS and Static Bypass need to be supplied by the same source.

Transfer the UPS to Maintenance Bypass Mode:

1. The normal start position should be following:

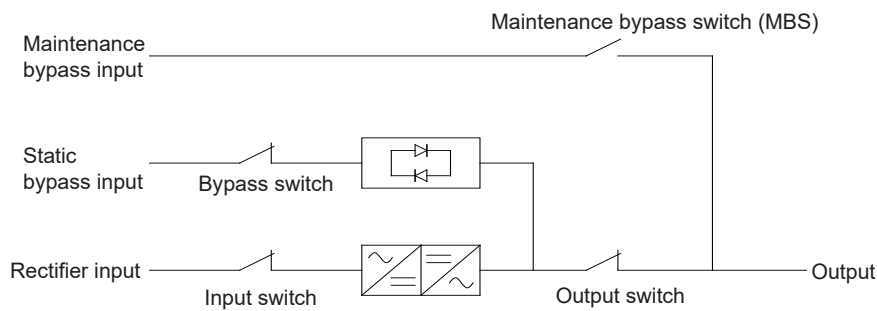

Figure 6-44: Double Conversion Mode

2. Perform transfer from double conversion mode to bypass mode as described in Section [6.3.3 Transfer from Double Conversion Mode to Bypass Mode](#). Remember to verify the transfer before proceeding to the next step.
3. Turn the MBS from UPS position to Bypass position.
4. Perform the LOAD OFF procedure in Section [6.3.7 UPS System and Critical Load Shutdown](#).
5. Turn OFF the rectifier switch to disconnect UPS rectifier input.
6. Turn OFF the output switch to disconnect UPS Inverter output.
7. Turn OFF the bypass switch to disconnect UPS bypass input.

UPS is now in the Maintenance Bypass Mode:

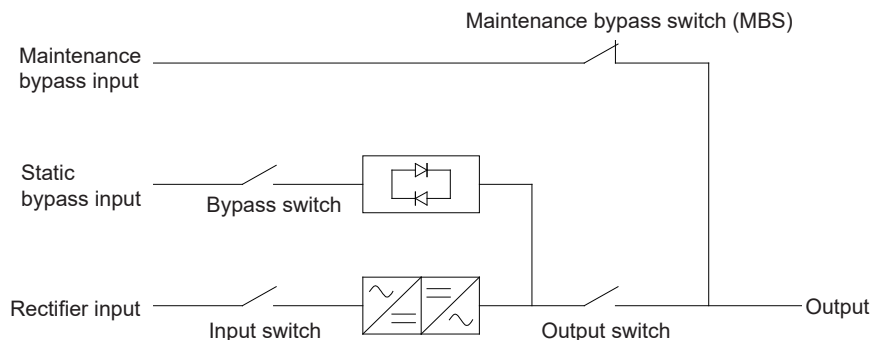

Figure 6-45: Maintenance Bypass Mode

6.7. Transfer UPS from Maintenance Bypass to Double Conversion Mode

To transfer the UPS back to Double Conversion Mode:

1. The normal start position should be the following:

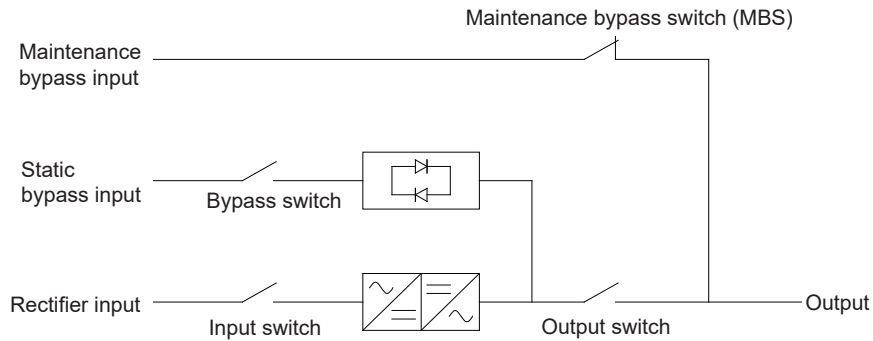

Figure 6-46: Maintenance Bypass Mode

2. Turn ON the rectifier switch to connect rectifier input to UPS.
3. Turn ON the Static bypass switch to connect UPS bypass input.
4. Turn ON the output switch to connect UPS Inverter output.
5. Perform the UPS start-up procedure (bypass mode) in Section [6.3.2 Starting the UPS System in Bypass Mode](#).
6. Turn OFF the MBS, and cut off the UPS maintenance bypass (MBS) output.
7. Refer the Section [6.3.4 Transfer from Bypass to Double Conversion Mode](#) to Double Conversion Mode.

The UPS is now in Double Conversion Mode

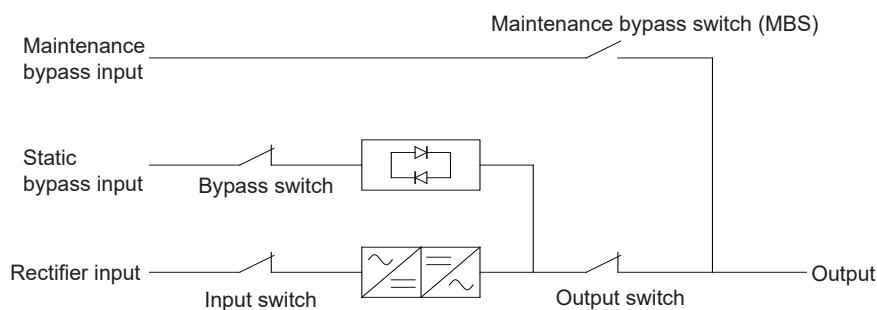

Figure 6-47: Double Conversion Mode



Chapter 7 UPS MAINTENANCE

The components inside the UPS cabinet are secured to a sturdy metal frame. All repairable parts and assemblies are located for easy removal, with very little disassembly. This design allows authorized service personnel to perform routine maintenance and servicing quickly. You must schedule periodic performance checks of your UPS system to keep it running properly. Regular routine checks of operation and system parameters enable your system to function efficiently for many trouble-free years.

7.1. Important Safety Instructions

Remember that your UPS system is designed to supply power **EVEN WHEN DISCONNECTED FROM THE UTILITY POWER**. The UPS module interiors are unsafe until the DC power source is disconnected and the electrolytic capacitors are discharged. After disconnecting the utility power and the DC power, authorized

service personnel should wait at least five minutes for capacitor bleed-off before attempting internal access to the UPS module.



NOTE

- **Servicing and maintenance should be performed by qualified service personnel only.**
- **LETHAL VOLTAGE PRESENT. This unit should not be operated with the cabinet doors open or protective panels removed. Do not make any assumptions about the electrical state of any cabinet in the UPS system.**

Since each battery string is an energy source in itself, opening the battery circuit breaker does not deenergize the voltage within the battery string. **DO NOT ATTEMPT TO ACCESS ANY INTERNAL AREA OF THE**

BATTERY STRING YOURSELF. VOLTAGES ARE ALWAYS PRESENT IN THE BATTERY STRING.

If you suspect that a battery string needs service, you should contact your service representative.

If the string requires service, refer to the battery manufacturer's operating manual for instructions on battery maintenance or contact your service representative.

Observe these precautions when working on or around batteries:

- Remove watches, rings, or other metal objects.
- Use tools with insulated handles.
- Wear rubber gloves and boots.
- Do not lay tools or metal parts on top of batteries or battery cabinets.
- Disconnect the charging source prior to connecting or disconnecting terminals.
- Determine if the battery is inadvertently grounded. If it is, remove the source of the ground. Contact with any part of a grounded battery can result in electrical shock. The likelihood of such shock is reduced if such grounds are removed during installation and maintenance.
- When replacing batteries, use the same number of sealed, lead-acid batteries.
- Proper disposal of batteries is required. Refer to your local codes for disposal requirements.

7.2. Performing Preventive Maintenance

The UPS preventive maintenance including inspection and annual maintenance is necessary, suggest it's carried by Santak professional engineer to ensure the UPS and battery are working in normal status.

Majority of the work must be performed by Santak authorized service personnel. Only the actions described in Section [7.2.1 DAILY Maintenance](#) and Section [7.2.2 MONTHLY Maintenance](#) are allowed for the user.

7.2.1. DAILY Maintenance

Perform the following steps daily:

1. Check the area surrounding the UPS system. Ensure the area is not cluttered, allowing free access to the unit.
2. Ensure the air intakes (vents on the front doors) and exhaust opening (the back of the UPS cabinet sections) are not blocked.
3. Ensure the operating environment is within the parameters specified in Section [3.2.1 Environmental and Installation Considerations](#) and [Chapter 8 TECHNICAL DATA](#).
4. Ensure the UPS is in Normal Mode (Normal status indicator is illuminated). If an alarm lamp is illuminated or the Normal status indicator is not illuminated, contact your service representative.

7.2.2. MONTHLY Maintenance

Perform the following steps monthly:

1. Monitor system parameters on the control panel in Section [6.2 Steps to operate the UPS](#).
2. If the optional air filters are installed, check them (located behind the front doors) and wash or replace as necessary. Contact your service representative for replacement filters. To replace the filters:
 - a. Open the front door latch and swing the doors open.
 - b. Replace the filters.
 - c. Close the doors and secure the latch.
3. Record the check results and any corrective actions in a suitable log.

7.2.3. PERIODIC Maintenance

Periodic inspections of the UPS should be made to determine if components, wiring, and connections exhibit evidence of overheating. Particular attention should be given to bolted connections. Maintenance procedures should specify that the bolted connections be re-torqued.



NOTE

Work on energized circuit must be performed only by authorized personnel.



7.2.4. ANNUAL Maintenance

Annual preventive maintenance should be performed only by authorized service personnel familiar with maintenance and servicing of the UPS system. Contact your service representative for more information about service offerings.

7.2.5. BATTERY Maintenance

Contact your service representative for battery maintenance. Battery replacement and maintenance should be performed only by authorized service personnel.

7.3. Recycling the Used UPS or Batteries

Before scrapping UPS or its battery cabinet, the battery bank must be removed. Local requirements must be followed in battery recycling or discard. The removal of batteries is allowed only by authorized service personnel due to high energy and voltage.

Do not discard waste electrical or electronic equipment in the trash. For proper disposal, contact your local collecting/recycling/reuse or hazardous waste center and follow the local legislation.

These symbols indicate on a product:



Figure 7-1: WEEE Symbol

Use proper local collecting centers meeting local legislation when handling waste of electrical and electronic equipment.



DANGER

HAZARDOUS MATERIALS. Batteries may contain **HIGH VOLTAGES**, and **CAUSTIC**, **TOXIC** and **FLAMMABLE** substances. Batteries can injure or kill people and damage equipment if used improperly. **DO NOT DISCARD** unwanted batteries or battery material in the public waste disposal system. Follow **ALL** applicable, local regulations for storage, handling and disposal of batteries and battery materials.



Figure 7-2: Recycling Batteries Symbol

7.4. Maintenance Training

For more information about training and other services, contact your Santak representative.

Chapter 8 TECHNICAL DATA

For complete technical specification, contact your Santak representative. Due to continuous product improvement programs, specifications are subject to change without notice.

8.1. Standards

Table 8-1: Standards

Safety	IEC 62040-1, IEC 60950-1
EMC, Emissions	IEC 62040-2 2005
EMC, Immunity	IEC 61000-2-2 (Low-frequency conducted) IEC 61000-4-2 (ESD) IEC 61000-4-3 (RF electromagnetic field) IEC 61000-4-5 (Surge) IEC 61000-4-6 (Conducted RF common mode) IEC 61000-4-8 (Power frequency magnetic field)
Performance & Tests	IEC 62040-3 2011
Environmental	IEC 62430
RoHS	2002/95/EC
WEEE	2002/96/EC
ECO Design Directive	2009/125/EC
Batteries	2006/66/EC
Packaging	94/62/EC



8.2. UPS System Input

Table 8-2: UPS System Input

Rated Input Voltage	220/380 V; 230/400 V; 240/415 V
Voltage Tolerance, (Rectifier Input)	301 ~ 478 V Line voltage
Voltage Tolerance, (Bypass Input)	175 ~ 276 V Phase voltage
Rated Input Frequency	50 or 60 Hz, user configurable
Frequency Tolerance	40 to 72 Hz
Number of Input Phases, (Rectifier Input) Number of Input Phases, (Bypass Input)	3 phases + N (Optional)
Input Power Factor	> 0.99
Rated Mains Input Current Maximum Mains Input Current	See Table 3-10 Rated and Maximum Currents for Rated Power and Voltage (unit:A)
Input Current Distortion at Rated Input Current, iTHD	< 3%
Rectifier Ramp-up, Rectifier Start and Load Step	5 A/s per UPM (default), configurable. Min 1A/s per UPM
Backfeed Protection	Yes, for rectifier and bypass lines

8.3. UPS System Output

Table 8-3: UPS System Output

Number of Output Phases	3 phases + N (Optional)
Rated Output Voltage	220/380 V; 230/400 V; 240/415 V, configurable
Total Voltage Harmonic Distortion	100% Linear Load < 1% 100% Non-Linear Load < 5%
Rated Output Frequency Output Frequency Variation Slew Rate	50 or 60 Hz, configurable $\pm 0,1$ Hz 1 Hz/s
Overload Capability at Ambient 30°C (Ambient Temperature)	10 min 125% load
Overload Capability at Ambient 30°C (Double Conversion Mode)	60 min 102-110 % load 10 min 111-125 % 30 sec 126-150 % load 300 ms > 150 % load
Overload Capability at Ambient 30°C (on Inverter, Stored Energy Mode)	1 min 102-110 % load 300 ms > 110 % load
Overload Capability at Ambient 30°C (on Bypass)	Continuous < 115% load, 10 ms 1000% load Note! Bypass fuses may limit the overload capability.
Output Current	See Table 3-10 Rated and Maximum Currents for Rated Power and Voltage (unit:A)
Load Power Factor, (Rated)	1.0
Load Power Factor, (Permitted Range)	From 0.8 lagging to 0.8 leading

8.4. Battery Specification

Table 8-4: Battery Specification

Battery Type	VRLA, 12 Vdc
Battery Quantity	36-44 blocks, 216-264 cells per battery string, default 40 blocks per battery string: 36 blocks, Module derating to 50kW 38 blocks, Module derating to 55kW 40 blocks, Module 60kW Note! Battery strings with different battery quantity and voltage may not be connected in parallel!
Battery Voltage	432V (36 blocks) to 528V (44 blocks)
Recharge Profile	ABM or float charge
End of Discharge Voltage	1.67 VPC to 1.75 VPC, configurable or automatic (load adaptive)
Charge Current	Configurable: 400kW 28A-280A configurable, default 175A @ 60% load; 500kW 32A-320A configurable, default 200A @ 60% load; 600kW 40A-400A configurable, default 250A @ 60% load;
Battery Start Option	Yes
Battery Environment	Discharge: -20°C~ +50°C Charging: 0°C~ +40°C Storage: -15°C~ +40°C Recommended working and storage temperature: +25°C

Note! For external battery connection, 48 Vdc Shunt release signal wiring from the UPS must be connected to the auxiliary signal connection of the battery breaker.

8.5. UPS Environmental Specifications

Table 8-5: UPS Environmental Specifications

Ambient Service Temperature Range, (UPS)	+0°C to +30°C (32°F ~ 86°F), No output power derating required.
Ambient UPS Storage Temperature Range	From -25°C to +55°C (-13°F ~ -131°F) in the protective package*
Maximum Service Altitude	Should UPS be intended for application above 2000m, contact your service representative for important information about high altitude operation.
Relative Humidity Range	5 to 95%, no condensation allowed There shall be at least a 1.8°F (1.0°C) difference between the dry bulb temperature and the wet bulb temperature, always, to maintain a non-condensing environment.
Acoustic Noise at 1 m	At 1m per ISO 7779 standard 300kW : ≤ 74.6dB 600kW : ≤ 78.8dB 1200kW : ≤ 81.8 dB
EMC	Class: C3 (GB 7260.2 / IEC 62040-2)



Suggested storage environment and storage time of UPS and spare parts:

- Equipment which cannot be immediately installed and energized should be stored in an indoor, dry, clean, ventilated area, heated environment (i.e. an temperature and humidity controlled environment). The storage area must be protected from rain, water, chemical agents and gases as shown in [Table 8-6](#). Meet the transportation and storage environment requirements of [Table 8-7](#) within one year of storage.
- Do not store in areas where conditions such as dampness, changes in temperature, dust, dirt, rubble, paint, conductive particulates, or corrosive atmosphere / gases are present.
- Factory installed packaging and wrapping of the equipment should not be removed until equipment is ready to install.
- It is the responsibility of the receiving contractor to ensure protection during storage.
- Equipment should be placed on true and solid level surfaces for storage.
- Have a plan for condensation and environmental mitigation prior to equipment arrival.
- This product was designed for installation and use in a G1 environment as defined in ANSI/ISA-71.04-2013. Refer to [Table 8-6](#) for gas concentration limits.

Table 8-6: Information copied from Table B1 of ANSI/ISA-71.04-2013 for G1 equipment

Contaminant	Gas	Gas Concentration in ppbv
Group A	H ₂ S	<3
	SO ₂ SO ₃	<10
	Cl ₂	<1
	NOx	<50
Group B	HF	<1
	NH ₃	<500
	O ₃	<2

Table 8-7: Meet the transportation and storage environment requirements

Storage condition for UPS and spare parts store one year (refer unit SN).	
Place	Indoor
Dusty	Well
Storage Temperature	<40°C
Storage Humidity	< 70% RH
Other	With original package

Please re –evaluate the storage time if can not meet above storage condition.

Chapter 9 WARRANTY

The product is warranted against defects in materials and workmanship for a period of thirty-six (36) months from its original date of purchase. The local office or distributor may grant a warranty period different to the above. Please refer to local terms of liability as defined in the supply contract.

The UPS manufacturer is not responsible for

- Any costs resulting from a failure if the installation, commissioning, repair, alternation, or ambient conditions of the equipment do not fulfill the requirements specified in the documentation delivered with the unit and other relevant documentation.
- Equipment subjected to misuse, negligence or accident.
- Equipment comprised of materials provided or designs stipulated by the purchaser.

The warranty is only valid if the installation inspection and initial start up of the UPS unit is carried out by a service engineer approved by Santak. Service and maintenance of the UPS shall also be performed only by a service engineer approved by Santak. Otherwise the warranty will be voided.

If the product fails to meet its published specifications due to a defect in material and workmanship, covered by this warranty, the seller will repair or replace the warranted product. Such repair or replacement will be made by Santak or by a service provider approved by Santak. Repair or replacement during the warranty period does not extend the original warranty. Warranty does not cover taxes, which will be due in connection with replacement or repair of the product.

Batteries are warranted against failures in material and workmanship, not against the normal aging and reduction of ampere-hour capacity. The product storage environment has to meet manufacturer's specifications, failure to do this will cause the warranty to be voided.

Under no circumstances shall the manufacturer, its suppliers or subcontractors be liable for special, indirect, incidental or consequential damages, losses or penalties.

The technical data, information and specifications are valid at the time of printing. The UPS manufacturer reserves the right to modifications without prior notice.



Chapter 10 INSTALLATION CHECKLIST

Installation Checklist

- All packing materials and restraints have been removed from each cabinet.
- The UPS cabinet is placed in its installed location.
- All conduits and cables are properly routed to the UPS and any ancillary cabinets.
- All power cables are properly sized and terminated.
- Neutral conductors are installed.
- A ground conductor is properly installed.
- Battery wire has correct polarity and installation.
- Building alarms are wired appropriately. (Optional)
- External battery breaker is off and can't be turned on as it is locked by UVT.
- Warning label is pasted on external battery breaker.
- LAN drops are installed. (Optional)
- LAN connections have been completed. (Optional)
- The REPO device is mounted in its installed location and its wiring is terminated inside the UPS cabinet. (Optional)
- A jumper wire is connected between pins 3 and 4 on the REPO terminal block if using a normally-closed REPO switch. (Optional)
- All terminal cover plates are installed.
- Accessories are mounted in installed locations and wiring is terminated inside the UPS cabinet. (Optional)
- Air conditioning equipment is installed and operating correctly.
- The area around the installed UPS system is clean and dust-free. (Eaton recommends that the UPS be installed on a level floor suitable for computer or electronic equipment.)
- Adequate workspace exists around the UPS and other cabinets.
- Adequate lighting is provided around all UPS equipment.
- A 230 Vac service outlet is located within 7.5 metres (25 feet) of the UPS equipment.
- Startup and operational checks are performed by an authorised Santak Customer Service Engineer, for parallel systems or installations with accessory cabinets.

Parallel System Installation Checklist

- Each cabinet in the parallel system is placed in its installed location.
- All conduits and cables are properly routed to the UPSs and to the parallel tie cabinet.
- All power cables are properly sized and terminated.
- Neutral conductors are installed between cabinets as required.
- Ground conductors are properly installed.
- CAN wiring between the UPSs is properly installed.
- Pull chain wiring between the UPSs is properly installed.
- Adequate workspace exists around the UPSs, parallel tie cabinet, and other cabinets.
- Startup and operational checks are performed by an authorised Santak Customer Service Engineer, for parallel systems.
- Battery wire has correct polarity and installation.
- External battery breaker is off and can't be turned on as it is locked by UVT.
- Warning label is pasted on external battery breaker.



Chapter 11 APPENDIX A: USER SETTINGS

The UPS has the following settings that are user modifiable. In the Home screen, select Settings. User settings:

Table 11-1: User Settings

To modify the Config settings, you need to sign in.

Setting	Description
Info	Information on the UPS model, including part number and serial number.
About	Version information.
Clear Status	Reset system Status.
Clear Alarms	Reset Sticky Alarms.

Table 11-2: Config Settings

Setting	Description
Language	Change the user interface language.
Unit Name	Change the unit name.
Clock	Change the date and time, change the clock for-mat or enable/disable NTP clock setup.
Signal Inputs	Select signal input name and function.
Relay Outputs	Configure the relay outputs.
Battery Test	Change the power level and duration for battery test.
Bypass Limits	Change bypass voltage, bypass frequency or by-pass slew rate limits.
Screen Saver Timeout	Change the screen saver timeout.
Meters	Change the meters format.
Lamp Test	Enable the lamp test.
HMI backlight	Adjust the backlight brightness.
Control P/W level 1	Change the level 1 password, or remove the password on level 1. The default value is 1111.
Config P/W level 2	Change the level 2 password.

www.santak.com.cn

SANTAK ELECTRICAL (SHENZHEN) CO., LTD

Address: No. 8 Baoshi Road, Bao'an District,
Shenzhen, 518101

E-mail: 4008303938@santak.com

Tel: 400-830-3938 / 800-830-3938

www.santak.com.cn