

# Type C Cutouts

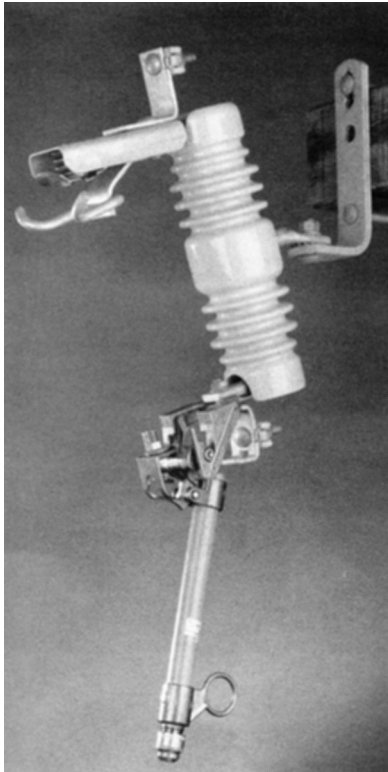

**STANDARD cutout,**  
pages 3-7

## Application

The primary purpose of any cutout is to provide protection to the lines of your system and the various apparatus on those lines such as transformers and capacitor banks. Chance Type C cutouts provide reliable protection from low-level overloads that just melt the fuse link, intermediate faults, and very high faults, through maximum interrupt capacity.

In addition, Type C cutouts can also be used as a sectionalizing device. With the use of a portable loadbreak tool, Type C cutouts can function much like an overhead disconnect switch. A 300 amp disconnect blade is also available for this purpose.

## Ratings/Specifications

STANDARD Type C cutouts have maximum design voltage ratings to simplify the confusing ratings of cutouts. There are **no restrictions** on application to grounded wye, ungrounded wye, or delta systems having maximum operating voltages (line-to-line) equal to or less than the cutout maximum design voltage rating. (See the LINKBREAK and LOADBREAK cutouts for their specifications.) Interruption tests have been performed at full system line-to-line voltage. In each voltage class, there are continuous current ratings of 100 amps, 200 amps and 300 amps. See the table on page 6 for other specifications.

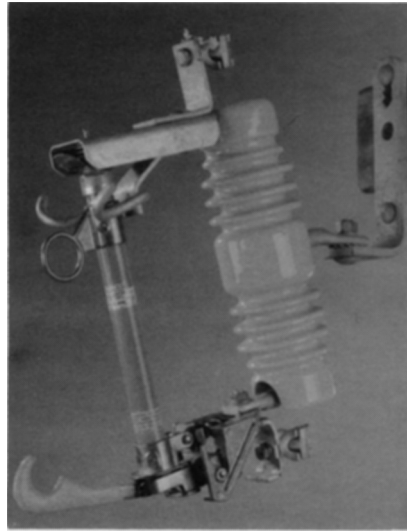

**LINKBREAK cutout,**  
pages 8-10

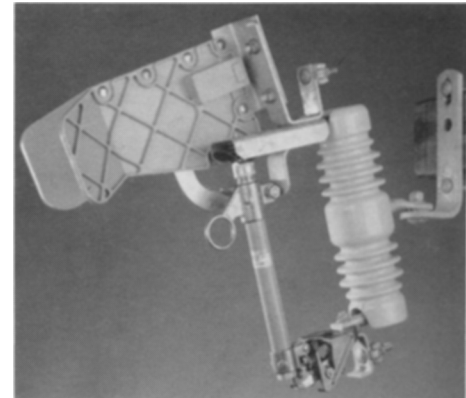

**LOADBREAK cutout**  
with Arc-Chute interrupter,  
pages 11-13

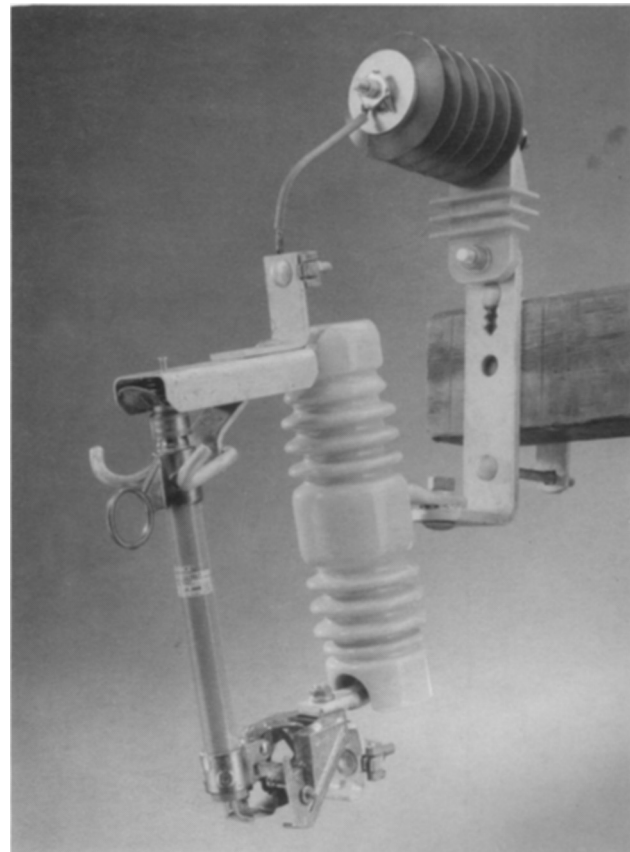

**CUTOUT-ARRESTER**  
Combinations,  
page 14

# Type C STANDARD Cutout

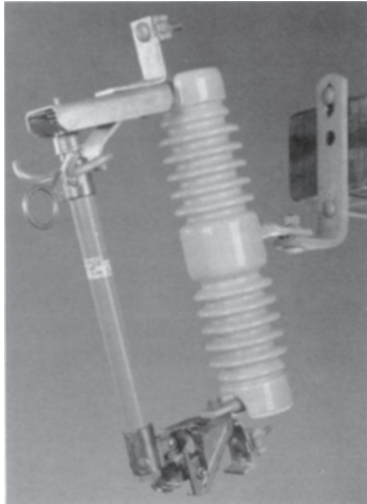

100 Amp — Single Vent

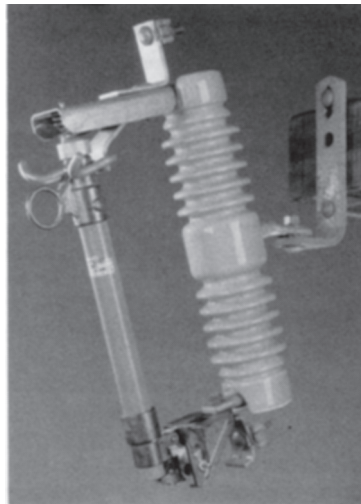

200 Amp — Single Vent



300 Amp — Disconnect

Chance Type C fuseholders are mutually interchangeable with S&C Type XS and ABB Type ICX cutouts.

## Quality Construction

### Efficient Current Transfer

The Chance Type C cutout has an all copper current path. All contacts are silver-plated. Terminals are tin-plated bronze for use with copper or aluminum conductors.

### Loadbreak Hooks

Galvanized steel hooks are standard on all Type C cutouts, except the arc chute version, for use with a portable loadbreak tool. These sturdy hooks are mounted on the top support and serve to guide the fuseholder into the latch socket when closing at an off-center angle.

### Top Contact

The top contact is attached to the galvanized-steel hood by a stainless rivet to provide a smooth self-aligning action during closing even in severely corrosive environments. The top contact provides a socket-type cavity for latching the fuseholder and prevents any possible “over-travel” of the fuseholder. The top contact is made of a highly conductive copper strip with silver-plated embossments to resist corrosion. The contacts are held under constant pressure designed to maintain firm contact with the fuseholder contact surface until fault interruption is accomplished.

### Hinge

The hinge on the Type C cutout employs large pivot areas for the fuseholder’s trunnion and is cast of a copper alloy chosen for its strength and corrosion resistance. The hinge contacts are highly conductive copper alloy stampings and are plated to assure low resistance current transfer from the trunnion casting. The parallel current paths are backed up by high strength cantilever springs and are riveted to the hinge castings. Fuseholder can be dropped into place and easily lifted up and out. No tricky maneuvering.

### Insulators

The insulators used on Type C cutouts are a sky-glaze gray. The metal to metal leakage distance on the 15 kV cutout insulator is 8.7 inches (220 mm), 12.6 inches (320 mm) on the 27 kV [125 kV LIW (BIL)], 17.3 inches (440 mm) on the 27 kV [150 kV LIW (BIL)], 26 inches (660 mm) on the 36 kV [170 kV LIW (BIL)], and 28.4 inches (720 mm) on the 36 kV [170 kV LIW (BIL)].

### Fuseholders

The solid cap on the single vent fuseholder is silver-plated copper alloy, to provide efficient current transfer. An integral ring is provided in the top tube casting for opening and closing the fuseholder with conventional disconnect tools from the ground, from a bucket truck or from the pole.

The **toggle type trunnion casting** is a selective **silver-plated bronze** for efficient current transfer to the lower hinge contacts. A cam shaped projection on each side of the trunnion casting provides high pressure parallel current paths to the lower contacts. These projections, or pivot pins, are cast full round for smooth rotational operation in the hinge. The link ejector assists in arc interruption during low fault current or excessive overload conditions. A groove in the center of the link ejector allows the fuse link’s pigtail to go directly from the fuse tube to the attachment nut. A curved ejector minimizes bending stresses in the pigtail to prevent broken strands. A stainless steel torsion spring on the link ejector helps to rapidly eject the link from the bore of the fuseholder during interruption. The 200 amp link ejector has a wider groove area and increased spring force to accommodate the larger links.

The **link ejector** is pinned to the trunnion casting with a stainless steel pin to provide resistance to corrosive elements and provide smooth pivotal action. An interlocking feature between the link ejector and tube casting prevents excessive tension on the fuse link during closure, thereby preventing link breakage.

The **link ejector** employs a hammer effect to enhance toggle action of the trunnion during low fault and overload interruptions, hence dropout action is enhanced. The link ejector provides sufficient surface area to facilitate re-fusing by linemen wearing gloves.

# Type C STANDARD Cutout

## PRODUCT FEATURES

### Interchangeability

Chance was the first to design a cutout that could interchange fuseholders and mounting assemblies with those of another manufacturer. Chance Type C fuseholders are mutually interchangeable with S&C Type XS and ABB Type ICX cutouts (within the same voltage class).

### Fusetube

The 1/2-inch inside diameter of the Type C cutout's 100 ampere fusetube increases internal pressure giving superior and reliable expulsion action. During frequently encountered intermediate fault ranges this diameter also permits higher TRV (transient recovery voltage) values to be tolerated. This small bore design eliminates any concern related to high impedance phase-to-phase faults on ungrounded wye and delta systems.

The inside liner is constructed of a synthetic arc-quenching material. The tube is made of fiberglass which permits the smaller bore and provides a higher burst strength. It is protected from the weather and environment by a special ultra-violet resistant coating.

Also, the Chance fusetube operates with fuselinks from all major suppliers.

### Brackets

C cutouts come packed one per carton including a NEMA Heavy Duty "B" bracket with captive 1 1/2" bolt for crossarm mounting.

Type X brackets, also for crossarm mounting, provides 2 5/8" additional clearance between the crossarm and the cutout.

"D" brackets are used to mount cutouts and/or arresters directly to the pole. Three brackets may be used for three-phase application. Type D brackets provide a clean, quick mounting without crossarm or special pole bands.

All the above brackets are galvanized steel for long lasting service. Cutouts can be ordered without any brackets.

### Higher Interrupt Capacities

By using a copper arc shortening rod inside the top of the fusetube, higher interrupt ratings are obtainable. An arc shortening rod is attached to the cap of some fusetubes and lowers the fuse link within the fusetube. This permits a much shorter arc, resulting in less arc energy, and higher interrupting capacities.

For 200 A tubes, it allows for full voltage rating.

It is necessary to use fuse links with removable buttonheads when arc shortening rods are employed.

### 170 kV LIW (BIL)

A 170 kV BIL Type C cutout is available for use in areas where the 28.4-inch minimum leakage distance to ground is required. See ordering data, page 6.

### Extra Corrosion Protection

Type C cutouts are available with stainless steel hood, brackets, and hardware and copper alloy loadbreak hooks to offer greater corrosion resistance for environmental areas where corrosion can become a major factor. To order a stainless steel/copper alloy cutout add the suffix "S" to the end of the catalog number with the rating specifications desired. In addition, an optional spring assist may be provided to further enhance the toggle and drop out action in highly corrosive applications.

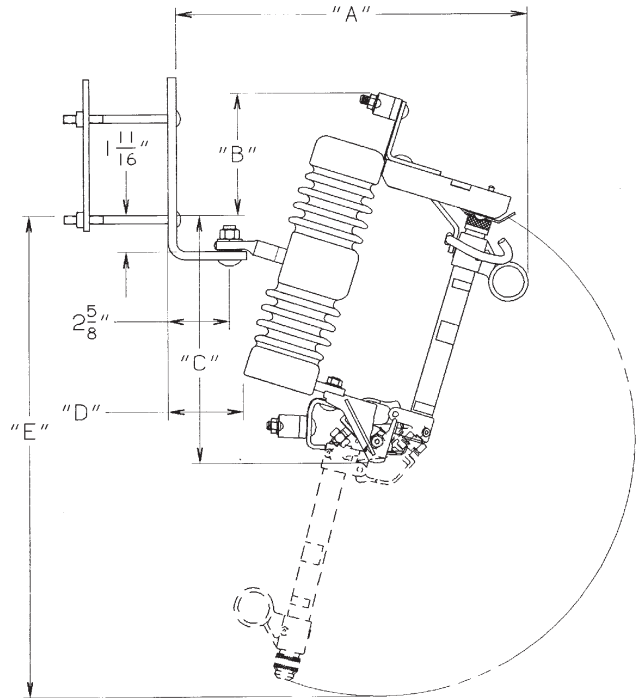

**STANDARD Type C Cutout with NEMA Type B Bracket Dimensions**

kV LIW (BIL)	A	B	C	D	E
110	16"	5 1/2"	10 3/4"	3 1/2"	21 1/2"
	406 mm	137 mm	273 mm	89 mm	559 mm
125	16 3/8"	7 1/8"	12 1/2"	3 1/8"	26 3/4"
	416 mm	181 mm	318 mm	79 mm	679 mm
150	16 3/8"	7 1/8"	12 1/2"	3 1/8"	26 3/4"
	416 mm	181 mm	318 mm	79 mm	679 mm
170	17 1/4"	8 1/2"	15"	1 3/4"	32 1/2"
	438 mm	216 mm	381 mm	44 mm	826 mm

### Terminals

Tin-plated bronze parallel groove type terminals are standard on Type C cutouts. They can accommodate aluminum or copper conductor sizes ranging from No. 6 (13.3 mm<sup>2</sup>) solid copper through 4/0 (160.6 mm<sup>2</sup>) ACSR or 250 (167.5 mm<sup>2</sup>) kcmil stranded copper. The parallel groove design is perfect for handling two different sizes of conductor as is the case when arresters are being used. Eyebolts are also available. See ordering data, page 10A-6.

# Compare Chance<sup>®</sup> quality and technical expertise Type C STANDARD Cutout

All Type C Cutouts meet or exceed ANSI/NEMA specifications.

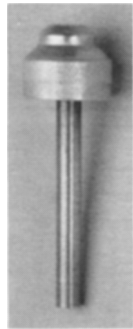

COPPER  
ARC-SHORTENING ROD  
(ON SOME RATINGS)

STAINLESS STEEL  
BACKUP SPRING  
TO MAINTAIN  
CONTACT PRESSURE

SILVER-TO-SILVER  
CONTACTS

GALVANIZED STEEL HOOKS  
FOR LOADBREAK TOOL

CAST BRONZE TOP TUBE CASTING  
AND PULL RING

HIGH-STRENGTH FIBERGLASS FUSE TUBE  
COATED WITH ULTRA-VIOLET INHIBITOR

HOT STICK HOLE IN TRUNNION CASTING

LARGE NUT OR  
SS NUT WITH  
CLAMP TO FASTEN  
FUSELINK WITH-  
OUT BREAKING  
STRANDS.

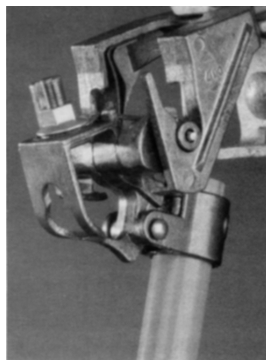

MECHANICAL ASSIST:

FUSEHOLDER IS AVAIL-  
ABLE WITH A TORSIONAL  
SPRING ON TRUNNION TO  
AID DROP OUT OPERATION  
IN CORROSIVE ENVIRON-  
MENTS.



CAST BRONZE  
LOWER TUBE  
CASTING

STAINLESS-STEEL  
SPRING ENSURES  
PROPER TOGGLE ACTION  
OF FUSELINK EJECTOR

FUSEHOLDER TOGGLE LATCH  
LIMITS TENSION OF FUSELINK

COPPER  
CURRENT PATH

SILVER-TO-SILVER  
CONTACTS  
WITH STAINLESS STEEL  
BACKUP SPRINGS

CAST BRONZE HINGE  
FOR CORROSION RESISTANCE

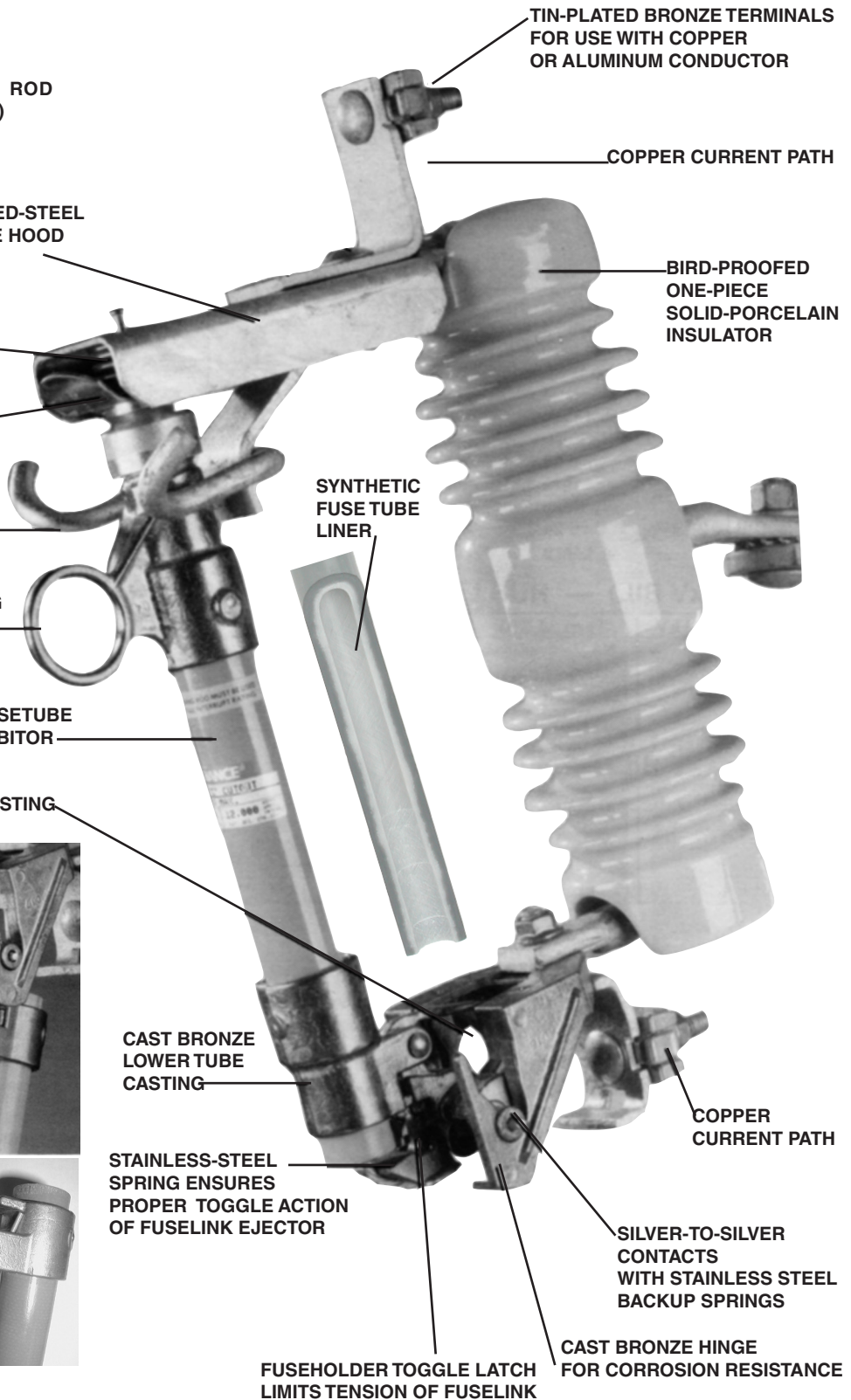

TIN-PLATED BRONZE TERMINALS  
FOR USE WITH COPPER  
OR ALUMINUM CONDUCTOR

COPPER CURRENT PATH

GALVANIZED-STEEL  
ONE PIECE HOOD

BIRD-PROOFED  
ONE-PIECE  
SOLID-PORCELAIN  
INSULATOR

SYNTHETIC  
FUSE TUBE  
LINER



# Type C STANDARD Cutout

## Specifications and Ordering Information

See page 10A-14 for Arrester Cutout Combinations  
See page 10A-15 for Accessories.  
See page 10A-16 for Complete Catalog Numbering

### 15 kV - 110 kV LIW (BIL) — RUS Listed

*Base Catalog No.	*Option suffixes below	Maximum Design Voltage	Nominal System Voltage	Continuous & Loadbreak Current (Amps)	Interrupt Capacity (Asym Amps)	Leakage to Ground Metal to Metal (minimum)		*Weight (lb./kg.)	Replacement Fusetube Cap/ Cap Assembly	Arc Shortening Rod
C710112	<u>1</u> <u>2</u> <u>3</u>	15 kV	Thru 14.4 kV	100	10,000	8.7"	220 mm	14.23 / 6.45	P7001535P	No
C710114	<u>1</u> <u>2</u> <u>3</u>	15 kV	Thru 14.4 kV	100	16,000	8.7"	220 mm	14.43 / 6.55	E7001767P	Yes <sup>‡</sup>
C710143	<u>1</u> <u>2</u> <u>3</u>	15 kV	Thru 14.4 kV	200	12,000	8.7"	220 mm	15.03 / 6.82	E7002146P	Yes <sup>‡</sup>
C710133	<u>1</u> <u>2</u> <u>3</u>	15 kV	Thru 14.4 kV	300	12,000**	8.7"	220 mm	14.53 / 6.59	P7001535P	N/A

### 27 kV - 125 kV LIW (BIL) — RUS Listed

C710211	<u>1</u> <u>2</u> <u>3</u>	27 kV	Thru 24.9 kV	100	8,000	12.6"	320 mm	17.03 / 7.72	P7001535P	No
C710213	<u>1</u> <u>2</u> <u>3</u>	27 kV		100	12,000	12.6"	320 mm	17.03 / 7.72	E7001768P	Yes
C710242	<u>1</u> <u>2</u> <u>3</u>	27 kV		200	10,000	12.6"	320 mm	17.73 / 8.04	E7002479P	Yes
C710243	<u>1</u> <u>2</u> <u>3</u>	27 kV		200	12,000	12.6"	320 mm	17.73 / 8.04	PSE7002706P	Yes
C710233	<u>1</u> <u>2</u> <u>3</u>	27 kV		300	12,000*	12.6"	320 mm	17.23 / 7.82	P7001535P	N/A

### 27 kV - 150 kV LIW (BIL) — RUS Listed

C710311	<u>1</u> <u>2</u> <u>3</u>	27 kV	No Restrictions thru 24.9 kV; 26.4 thru 34.5kV	100	8,000	17.3"	440 mm	22.63 / 10.26	P7001535P	No
C710313	<u>1</u> <u>2</u> <u>3</u>	27 kV		100	12,000	17.3"	440 mm	22.83 / 10.36	E7001768P	Yes
C710342	<u>1</u> <u>2</u> <u>3</u>	27 kV		200	10,000	17.3"	440 mm	23.43 / 10.63	E7002479P	Yes
C710343	<u>1</u> <u>2</u> <u>3</u>	27 kV		200	12,000	17.3"	440 mm	23.43 / 10.63	PSE7002706P	Yes
C710333	<u>1</u> <u>2</u> <u>3</u>	27 kV		300	12,000*	17.3"	440 mm	23.03 / 10.45	P7001535P	N/A

### 36 kV - 170 kV LIW (BIL) — RUS Listed

C710613	<u>1</u> <u>2</u> <u>3</u>	36 kV	Thru 34.5 kV	100	12,000	26"	660 mm	25.43/11.54	E7001743P	Yes <sup>‡</sup>
C710643	<u>1</u> <u>2</u> <u>3</u>	27 kV	No Restrictions thru 24.9 kV; *26.4 thru 34.5 kV	200	12,000	26"	660 mm	25.83/11.72	E7002117P	Yes <sup>‡</sup>
C710633	<u>1</u> <u>2</u> <u>3</u>	36 kV	Thru 34.5 kV	300	12,000**	26"	660 mm	25.43/11.54	P7001535P	N/A

NOTE: 26" fuse links are recommended.

### 36 kV - 170 kV LIW (BIL) — RUS Listed

C710713	<u>1</u> <u>2</u> <u>3</u>	36 kV	Thru 34.5 kV	100	12,000	28.4"	720 mm	30.73/13.94	E7001743P	Yes <sup>‡</sup>
C710743	<u>1</u> <u>2</u> <u>3</u>	27 kV	No Restrictions thru 24.9 kV; *26.4 thru 34.5 kV	200	12,000	28.4"	720 mm	31.13/14.12	E7002117P	Yes <sup>‡</sup>
C710733	<u>1</u> <u>2</u> <u>3</u>	36 kV	Thru 34.5 kV	300	12,000**	28.4"	720 mm	30.73/13.94	P7001535P	N/A

NOTE: 26" fuse links are recommended.

\*Adjust total weight when selecting Options below. \*\*Momentary rating — Solid blade ‡Must use removable buttonhead fuse links.

†For application on single-phase to neutral or three-phase solidly-grounded wye-connected circuits where recovery voltage does not exceed the maximum-design voltage of the device.

#### \*Option Suffix 1

Terminal Variations

Suffix 1	Description	*Weight (lb./kg.)
P	Parallel-groove clamps	0.33/0.15
E	Small eyebolts	0.16 /0.07
L	Large eyebolts	0.31/0.14
R	Lower PG Clamp Rotated 90°	0.33/0.15

Must specify one selection for Option 1.

#### \*Option Suffix 2

Bracket Variations

Suffix 2	Description	*Weight (lb./kg.)
B	NEMA Heavy Duty "B" bracket for crossarm (1½" bolt)	2.84/1.29
X	Extended type bracket for crossarm (Horizontal section is 2⅝" longer than Type B bracket)	3.75/1.70
D	D-shape bracket (pole)	7.67/3.48
Z	No bracket (must be used with M in Option 3)	—
Blank	No bracket (cannot use with M in Option 3)	—
V	Easy-On bracket (Height: 4⅞" to 5⅝", Width: 2¾" to 4")	2.9/1.32

#### \*Option Suffix 3

Mechanical Assist Fuseholder

Suffix 3	Description
Blank	No option (may not be used with Z in Option 2)
M	Mechanical Assist Fuseholder (may not be used with Blank in Option 2)
F	Fargo cutout cover (may not be used with Blank in Option 2)
S	Anti- corrosion stainless steel/copper alloy cutout



# Type C STANDARD Cutout

## Fuseholders and Mounting Assemblies

### Ordering Information

#### 15 kV - 110 kV LIW (BIL)

*Cutout Base Catalog Number	Fuseholder/Blade Catalog Number	Fuse Holder/ Blade Weight		Mounting Assembly Base *Catalog Number	Mounting Assembly Weight	
C710112	T710112T	1.8 lb.	0.82 kg.	T7101MM	12.9 lb.	5.85 kg.
C710114	T710114T	2.0 lb.	0.91 kg.			
C710143	T710143T	2.6 lb.	1.18 kg.			
C710133	T710133T	2.1 lb.	0.95 kg.			

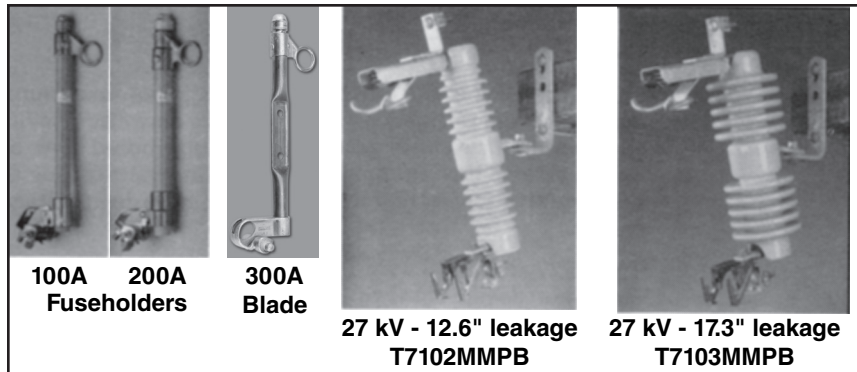
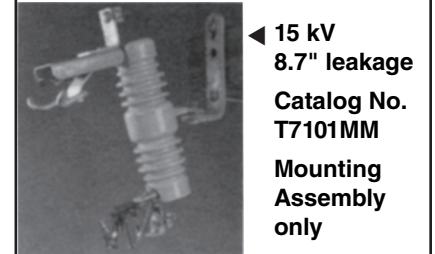
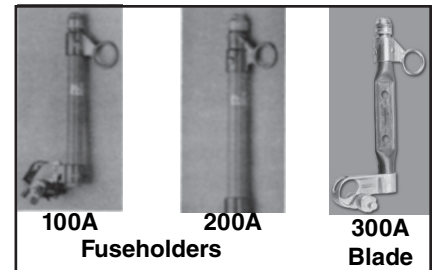

#### 27 kV - 125 kV LIW (BIL)

C710211	T710211T	2.1 lb.	0.95 kg	T7102MM	15.6 lb	7.08 kg
C710213	T710213T	2.3 lb.	1.14 kg			
C710242	T710242T	2.7 lb.	1.22 kg			
C710243	T710243T	2.7 lb.	1.22 kg			
C710233	T710342T	2.5 lb.	1.13 kg			

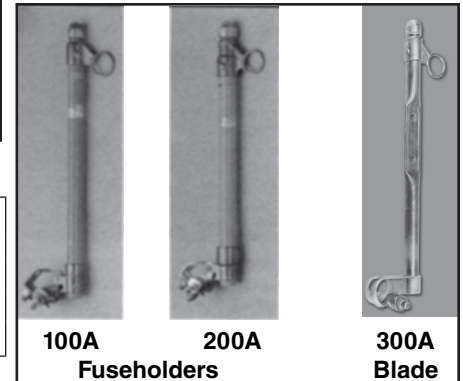

#### 27 kV - 150 kV LIW (BIL)

C710311	T710311T	1.9 lb.	0.86 kg	T7103MM	21.3 lb	9.66 kg
C710313	T710313T	2.0 lb.	0.91 kg			
C710342	T710342T	2.5 lb.	1.13 kg			
C710343	T710343T	2.5 lb.	1.13 kg			
C710333	T710333T	2.1 lb.	0.97 kg			

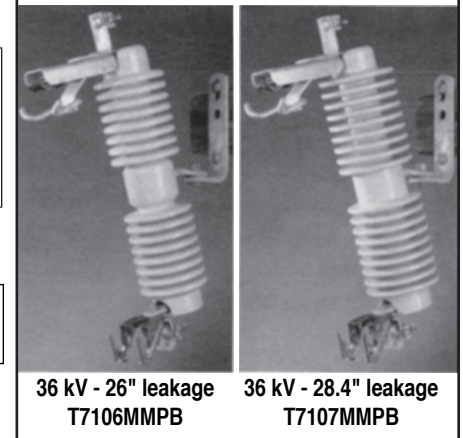

#### 36 kV - 170 kV LIW (BIL)

C710613	T710613T	2.8lb.	1.27 kg.	T7106MM	23.4 lb.	10.61 kg.
C710643	T710643T	3.2 lb.	1.45 kg.			
C710633	T710633T	2.8 lb.	1.27 kg.			

NOTE: 26" fuse links are recommended.

#### 36 kV - 170 kV LIW (BIL)

C710713	T710713T	2.8lb.	1.27 kg.	T7107MM	28.7 lb.	13.02 kg.
C710743	T710743T	3.2 lb.	1.45 kg.			
C710733	T710733T	2.8 lb.	1.27 kg.			

NOTE: 26" fuse links are recommended.

#### Universal Cutout Tool

Ideal for Standard and Linkbreak 100 amp fuse holders (ABB, Chance S&C) to easily lift out, place, \*open and close. Inverted, secure method also fits Chance Electronic Sectionalizers.

Cat. No. **PSC4033484** (Wt. 4 oz.) See Tools Catalog Section 2100.

\*When opening a cutout, follow all work rules and OSHA regulations. *Not for use with Loadbreak cutouts.*

