

EATON Low Voltage Capacitor and APF



E Series Low Voltage Capacitor

Application

Type EPLCR LV capacitors feature the Latest design for power quality solutions, widely used in a variety of applications and make a simple, economical reliable source for reactive power on electric power systems for improving power factor.

Type EPLCRLV capacitors are built on low losses, long life, self-healing, over pressure separator, highly reliable, and environmentally friendly.

Ratings

- Rated capacity: 0~50kvar
- Rated voltage: 200V~ 525V
- Frequency: 50Hz/60Hz
- Permissible current: 1.3x IN for continuous operation
- Permissible voltage: 1.1x UN for continuous operation
- Losses: $\leq 0.02\text{W/Kvar}$
- Dielectric: Polypropylene
- Safety: Overpressure disconnecter
- Temperature category: -25/B (Dry Type), -25/D (Oil Type)
- Altitude: < 2000m
- Discharge capability: less than 50 Volts, within 3 minutes of de-energization
- Standard: IEC/GB

Advanced technology

- Easy to install with a threaded terminal under the aluminum case.
- Running safety with overpressure disconnecter and internal discharge resistor.
- Reducing the residual voltage to less than 50 Volts, within 3minutes of de-energization.
- Automatically shut down when a fault coming up to forbidden burning or explosion.
- Capacitor is made of metalized polypropylene film housed in recyclable aluminum case under a strict quality controlled process.



EATON

Powering Business Worldwide

Part Number Configuration

EPLCR Y 280 - 12 - 60

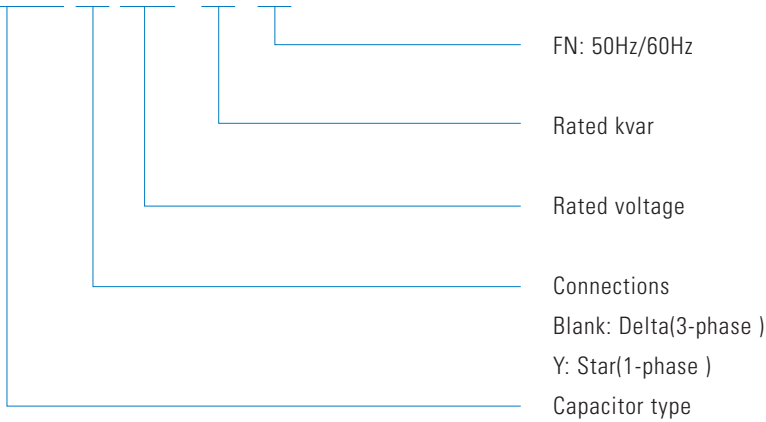

Connection:

Δ Delta (three-phase)

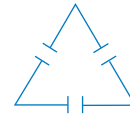

Y Star (single phase)

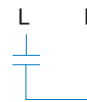

Order Information

E series are designed to meet all customized needs:

- Single phase capacitor type EPLCRY need 3 pcs for 3-phase compensation
- Capacitor should be designed to suit the reactive power compensation application when series reactor applied

Table1 Ratings for 60Hz

Type EPLCR ,3-phase Δ

280V 60Hz		400V 60Hz		480V 60Hz		525V 60Hz		600V 60Hz	
Q _N (kvar)	I _N (A)	Q _N (kvar)	I _N (A)	Q _N (kvar)	I _N (A)	Q _N (kvar)	I _N (A)	Q _N (kvar)	I _N (A)
12	24.7	12	17.3	12	14.4	12	13.2	12	11.5
18	37.1	18	26.0	18	21.7	18	19.8	18	17.3
24	49.5	24	34.6	24	28.9	24	26.4	24	23.1
30	61.9	30	43.3	30	36.1	30	33.0	30	28.9
36	74.2	36	52.0	36	43.3	36	39.6	36	34.6
		*42	60.6	*42	50.5	*42	46.2	*42	40.4
		*48	69.3	*48	57.7	*48	52.8	*48	46.2

* for oil type only.

Note: Capacitors themselves do not cause harmonics, but only aggravate potential harmonic problems, often, harmonic-related

problems do not "show up" until capacitors are applied for power factor correction, a series iron core reactor is recommended to combine with power factor correction in power systems with harmonics problem.

Construction Features

Construction features of Eaton LV capacitors include:

- Aluminum case for resistance to severely corrosive atmospheres. A threaded terminal is under the bottom of the case to fix the capacitor with a torque wrench, earthing is also achieved through fixation points.
- Copper terminals are supplied on all the capacitors sold as individual units, a plastic cover is to protect terminals from animals, metal conductors to damage the devices.
- Internal discharge resistor that reduce terminal voltage to 50V volts or less within three minutes after the capacitor has been disconnected.
- All the capacitors have a overpressure disconnector, this prevents the energy stored in the capacitor.

Type	U _N (V)	Q _N (kvar) /50Hz	Q _N (kvar)/60Hz	Dimensions		Configuration
				D×H (mm)	L(mm)	
EPLCR	280	10	12	116*235	28	
		15	18	116*235	28	
		20	24	136*235	35	
		25	30	136*235	35	
		30	36	136*280	35	
	400	10	12	76*235	24	
		15	18	86*250	24	
		20	24	116*235	28	
		25	30	116*235	28	
		30	36	116*250	28	
	480	10	12	76*235	24	
		15	18	86*235	24	
		20	24	116*235	28	
		25	30	116*235	28	
		30	36	116*235	28	
	525	10	12	76*235	24	
		15	18	86*235	24	
		20	24	116*235	28	
		25	30	116*235	28	
		30	36	136*235	35	
600	10	12	86*235	24		
	15	18	116*235	28		
	20	24	116*235	28		
	25	30	136*235	35		
	30	36	136*250	35		

Table 2 Dimensions

*Consult factory for detail dimensions or other ratings of capacitors that are not included in above sheet.

Eaton BLR-ACX power factor controller can switch the steps optimized and effectively . Settings can be done easily with friendly HMI and the auto-initialization function .



Technical Data

- Auxiliary Voltage: AC 90V-550V ,45-65Hz,5VA,Max.fuse 6A,
- Current Measuring: 15mA-6A,burden 20mOhm,CT ratio from 1 to 9600
- Control Exits: Up to 14 relays, N/O,with voltfree common point
- Measuring Display: V,A,Kva,kW,kvar,cosphi,PF, Δkvar,THDU,3rd to 19th harmonic of voltage
- Ambient Temperature: -20°C - 70°C
- Breaking Capacity: 250V AC/5A,400V AC/2A
- Temperature Measuring: By NTC
- Protection Class: Front IP50,Rear IP20
- Dimensions: 144x 144x 58mm hwxwd, cutout 138 x 138 mm

Available Versions

- BLR-ACX06 6 control exits
- BLR-ACX14 14 control exits

Options

- RS485 Modbus RTU ,USB

Wiring Diagram

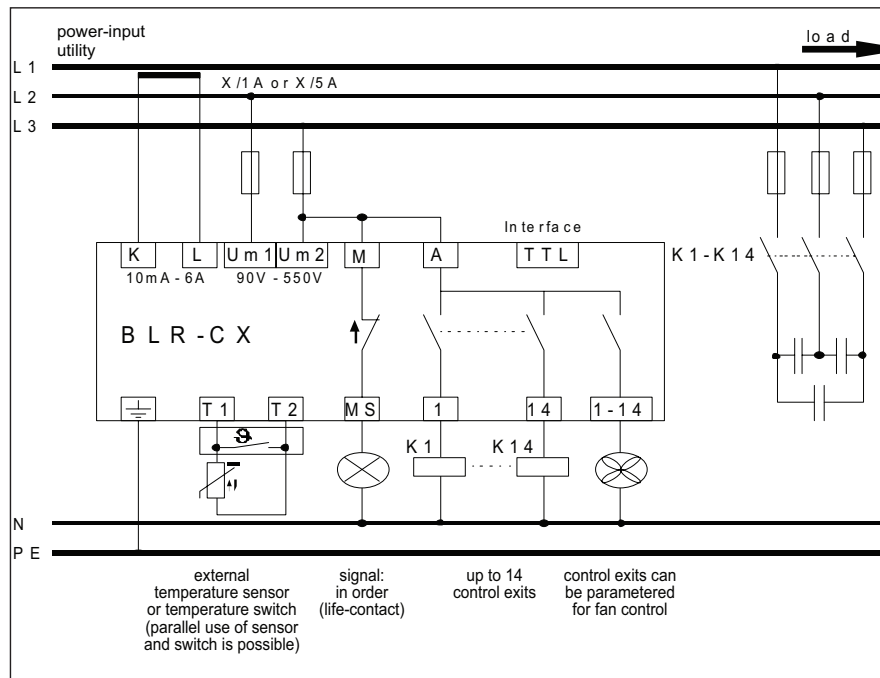

Active Power Filter



Eaton Cooper Power Series active power filter, using the IGBT-PWM converter and built-in advanced DSP technology, can rapidly and dynamically respond to the varying load and the frequency up to 60 kHz.

The principle of low voltage active power Filter

- The Eaton's Cooper Power Systems low voltage active power filter, is the latest professional harmonic elimination equipment, integrating advanced power electronics and DSP technology. It is composed of the arithmetic circuit and compensation current generation circuit.
- The arithmetic circuit keeps sampling the current and outputting the digital signal through the AD converter in real-time. The DSP calculates the digital signal to separate the fundamental waves and harmonics. Then the PWM waves are based on the calculation result and generated to control the IGBT power module. Thereby the compensation current is emitted to the circuit to eliminate the harmonics actively.

Product Features

- Storage temperature: $-40^{\circ}\text{C}\sim+70^{\circ}\text{C}$
- Operating temperature: $-10^{\circ}\text{C}\sim+50^{\circ}\text{C}$
- Related humidity: $< 95\%$
- Input voltage: $400\text{V}\pm 20\%$
- Frequency: $50/60\pm 10\text{Hz}$ (automatic detection)
- 2nd - 51st order
- CT ratio primary current 100 A~9999 A, secondary current 5A(optional 1A)
- Power outage release $< 20\text{ms}$
- open-loop control
- 5"Color LCD display panel
- DSP digital control technology
- Improving power factor, compensation automatically
- Elastic expansion
- Outstanding compensation of unbalanced three-phase
- Communication adapter: RS485
- Communication protocol: Modbus RTU
- Standard: EN61000-3-4, IEEE519-1992
- Design standard EN60146
- Electromagnetic compatibility standard: EN50178

User-friendly HMI

CELA APF is equipped with friendly HMI that includes power-on/power-off, active alarm control and system status checking. It can read electrical data and show the wave of current and voltage, spectrum of harmonic, etc. This can be easy and helpful to manage the data base of APF and power system, and read the data from the filter, load, and power source site. It can be operated via LCD display and operation panel.

- Complete data: voltage, current, frequency, power factor ,power, harmonic
- Wave and harmonic spectrum
- Control command and setting
- Event record
- Multi-language

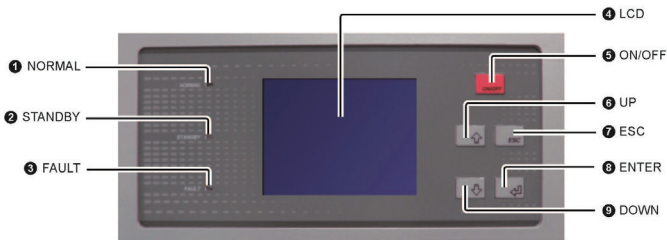

Ease of Installation and Maintenance

CELA APF offers standard enclosed module and bank , it comes standard with a digital interface module for control, diagnostics and programming. Verification prior to installation that all APF modules prerequisites have been met. This can be stacked directly while installing with no upper limit of modules connected in parallel.

- Fixed by screws for ease of remove and installation
- Reduce installation time
- Fully assembled ,completely self –contained , test and ready to install
- Low profile and easily accessible to field maintenance crews
- Regular inspection and cleaning



Notes:

- CTs (5A/1A)is required for APF module.
- 5A is standard design , consult factory for 1A module

Rating based on Service Entrance Ampacity and optional parallel operation.

Consult factory for special connections

Sizing and Product Selection

MODULE	VOLTAGE	AMPERES (RMS)	HxWxD IN MM
CELA50	400	50	440x523x174
CELA75	400	75	440x523x174
CELA100	400	100	605x625x220

Notes:

- CELA is housed in an air-conditioned floor standing enclosure and include a main disconnect.
- Additional CTs required for parallel operation for CELAs.
- Rating based on Service Entrance Ampacity and optional parallel operation, consult factory for ratios and additional information.

CT Location

CTs for current detection located on the side of the harmonic source is recommended to feed the detection signal to the APF, see following figure

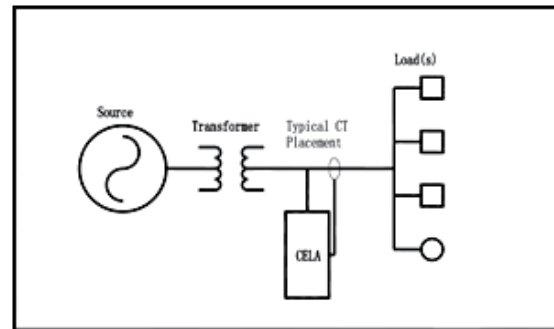

If capacitors are in the system for power factor corrections , CTs located between capacitor feeder and load is recommended as below

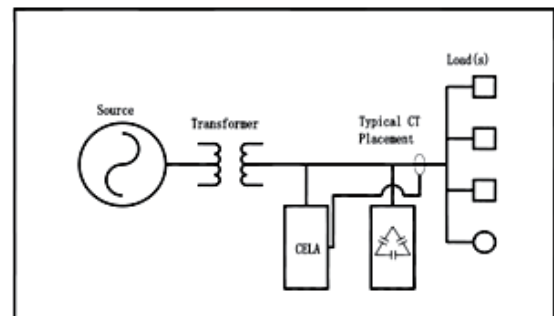

Notes:

Consult factory for any special cases .

CELA Active Power Filter

AMPERES (RMS)	System Voltage (V)	Frequency (Hz)	Module Type	Required Cabinet DIM.(WxDxH)(mm)
50	400	50/60	CELA50+1x LCM	1000x1000x2200
100			CELA100+1x LCM	
150			1xCELA50+1xCELA100+1x LCM	
200			2xCELA100+1x LCM	
250			1xCELA50+2xCELA100+1x LCM	
300			3xCELA100+1x LCM	
350			1xCELA50+3xCELA100+1x LCM	
400			4xCELA100+1x LCM	
450			1xCELA50+4xCELA100+1x LCM	
500			5xCELA100+1x LCM	

CELB Low-Voltage Reactive Power Compensation Cabinet

Overview

The Cooper CELB low-voltage tuning filter device uses filter capacitors connected in series with tuning reactors to form a tuning filter device. It can be switched by contactors and thyristors, and not only provides the function of improving the system power factor, but also effectively avoids system resonance, absorbs a certain amount of harmonics, and thus ensures the stable operation of the power supply system and electrical equipment.

Features

- With arc-pulling protection function, preventing the contactor from opening under load and ensuring the safety of operating personnel.
- The cabinet layout is neat and reasonable, and an automatic ventilation system is installed to reduce the internal working temperature of the cabinet and extend the service life of components.
- The tuning reactor adopts an iron-core copper-wound structure, with lower heat generation.
- The low-voltage thyristor-switched tuning filter device uses electronic components for switching, enabling fast conduction, no mechanical action points, and no arc-pulling.



Technical Parameters

Rated voltage:	220V-750V
Rated capacity:	120kVar – 444kVar (customizable)
Reactance percentage:	6%, 7%, 14%
Tuning frequency:	204Hz, 189Hz, 133Hz (customizable)
Ingress Protection:	IP20
Application location:	Indoor
Insulation level:	3kV/1min
Capacitor Discharge:	Voltage drops to below 50 V within 1 min
Ambient temperature:	-20°C - +40°C
Standards:	IEC60831, IEC60289, VDE0532 GB/T15576-1995, JB/T9663-1999
Enclosure color:	RAL7035 (customizable)

CELB Model Selection

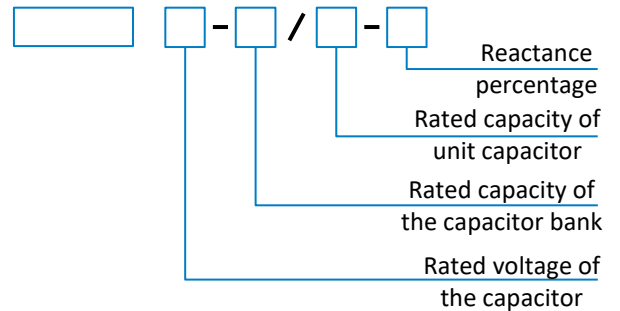

Reactive Power Compensation and Harmonic Suppression Solutions

According to different load types and characteristics, choose different compensation methods and provide different solutions.

- Contactor-switched three-phase capacitor bank.
- Thyristor-switched three-phase capacitor bank
- Thyristor-switched three-phase / single-phase capacitor bank.

Typical Configurations of Tuning Filter Cabinet

Model	Rated Voltage (V)	Rated total capacity (kVar)	Effective total capacity (kVar)	Rated capacity per section (kVar)	Reactance percentage (%)	Total current (A)
CELB480-600/100-6	480	600	444	100	6	720
CELB480-500/100-6	480	500	370	100	6	600
CELB480-400/100-6	480	400	296	100	6	480
CELB525-600/100-14	525	600	408	100	14	660
CELB525-500/100-14	525	500	340	100	14	550
CELB525-400/100-14	525	400	272	100	14	440

When designing complete sets, capacitor-reactor groups can be configured for different switching methods. Cooper's large-capacity capacitors offer more configuration options.

Typical Capacitor Configuration (CEL Series)		PFC CELP-12		PFC CELP-12		PFC CELP-12		PFC CELP-12	
		Reactor 4×CELR74/400-6 Capacitor 4×CELC480-100		Reactor 3×CELR74/400-6+2×CELR37/400-6 Capacitor 3×CELC480-100+2×CELC480-50		Reactor 5×CELR59/400-6 Capacitor 5×CELC480-80		Reactor 4×CELR59/400-6+2×CELR30/400-6 Capacitor 4×CELC480-80+2×CELC480-40	
Reactive Power Compensation	Switching Method	Contactor		Contactor		Contactor		Contactor	
	Power Factor Controller	CELP-12		CELP-12		CELP-12		CELP-12	
	Contactor (or Thyristor)	165A		165A/81A		130A		130A/65A	
	Reactor	CELR74/400-6 4sets		CELR74/400-6 3sets CELR37/400-6 2sets		CELR59/400-6 5sets		CELR59/400-6 4sets CELR30/400-6 2sets	
	Capacitor	CELC480-100 4sets		CELC480-100 3sets CELC480-50 2sets		CELC480-80 5sets		CELC480-80 4sets CELC480-40 2sets	
	Total Installed Capacity	400kVar		400kVar		400kVar		400kVar	
	Effective Capacity	296kVar		296kVar		295kVar		296kVar	
	Ratio	1:1:1:1		1:1:2:2:2		1:1:1:1:1		1:1:2:2:2:2	
W×D×H(mm)	800×1000×2200		1000×1000×2200		1000×1000×2200		1200×1000×2200		
Typical Capacitor Configuration (CELCR Series)		PFC CELP-12		PFC CELP-12		PFC CELPT-15		PFC CELPT-15	
		Capacitor 8×CELCR480-33.5-R Reactor 8×CELR25/400-7		Capacitor 2×CELCR480-33.5-R +2×CELCR480-33.5-R*2 Reactor 2×CELR25/400-7 +2×CELR50/400-7		Capacitor 4×CELCR280-10-R*3 Reactor 4×CELR7.5/400-7-1W*3		Capacitor 2×CELCR280-10-R*3 +1×CELCR280-20-R*3 Reactor 2×CELR7.5/400-7-1W*3 +1×CELR15/400-1-1W*3	
Reactive Power Compensation	Switching Method	Contactor		Contactor		Thyristor		Thyristor	
	Power Factor Controller	CELP-12		CELP-12		CELPT-15 TSI-		CELPT-15	
	Contactor (or Thyristor)	55A		55A/110A		400-40S		TSI-400-40S/TSI-400-60S	
	Reactor	CELR25/400-7 8sets		CELR25/400-7 2sets CELR50/400-7 2sets		CELR7.5/400-7-1W*3 4sets		CELR7.5/400-7-1W*3 2sets CELR15/400-1-1W*3 1sets	
	Capacitor	CELCR480-33.5-R 8sets		CELCR480-33.5-R 2sets CELCR480-33.5-R*2 2sets		CELCR280-10-R*3 4sets		CELCR280-10-R*3 2sets CELCR280-20-R*3 1sets	
	Total Installed Capacity	268kVar		268kVar		120kVar		120kVar	
	Effective Capacity	200kVar		200kVar		90kVar		90kVar	
	Ratio	1:1:1:1:1:1:1		1:1:2:2		1:1:1:1		1:1:2	
W×D×H(mm)	1200×1000×2200		1000×1000×2200		1000×1000×2200		1000×1000×2200		

Eaton is a power management company with 2016 sales of \$19.7 billion. Eaton provides energy-efficient solutions that help our customers effectively manage electrical, hydraulic and mechanical power more efficiently, safely and sustainably. Eaton has approximately 95,000 employees and sells products to customers in more than 175 countries. For more information, visit www.eaton.com.

Regional Office for Europe, Africa, India & the Middle East (EAIME)
19, Mykinon Str., GR-166 74 Glyfada (Athens) - GREECE
Tel: +30 210 964 6332
Fax: +30 210 964 6336

Regional Office for SE Asia - Singapore Office
No. 2, Serangoon North Avenue 5, #06-01, Fu Yu Building,
Singapore 554911
Tel: +65 6273 8225
Fax: +65 6273-8850

Eaton Electrical Australia Pty. Ltd.
205 Woodpark Road, Smithfield
NSW 2164, Australia
Tel: +61 2 87872777
Fax: +61 2 9609-2342

Eaton Industries International-Philippine Branch
29/F Ayala Life FGU Center
6811 Ayala Ave., Makati City, 1200 Philippines
Tel: +632 812 3045 to 47

Eaton

Cooper (Shanghai) Power Capacitor Co.,Ltd
No.955 Sheng Li Road,
East Area of Zhangjiang High-Tech Park,
Shanghai,China 201201
www.eaton.com

©2017 Eaton
All Rights Reserved
Printed in China
Publication No. B230-15033EN New Issue
March 2017



Eaton is
registered trademarks.

All other trademarks are property of
their respective owners.